

## TECHNICAL DATA

Description	Unit	MCU			
		Table ø600	Table ø500x420		
HIGH DYNAMIC TABLE	Rotary table top diameter	mm	ø600	ø500x420	
	Tilting axis A	degree	±120		
	Rotary axis C	degree	360		
	T-slots ( number x width x pitch )	mm	7 x 14 x 75	5 x 14 x 75	
	Max. table load	kg	600		
LINEAR TRAVEL	X axis	mm	600		
	Y axis	mm	600		
	Z axis	mm	500		
	Spindle taper		ISO40		
IN-LINE SPINDLE	Spindle speed	rpm	15000		
	Motor output	kW	25/35		
	Motor torque	Nm	134/239		
	Spindle nose to rotary table clamping surface	mm	135~635		
	Spindle taper		HSK-A63		
BUILT-IN SPINDLE	Motor output	kW	20/25		
	Motor torque	Nm	32/40		
	Spindle speed	rpm	18000(std.) / 24000(opt.)		
	Spindle nose to rotary table	mm	175~675		
	ATC type		Carousel type	Chain type	
TOOL MAGAZINE	Magazine capacity		24(std.)	32/48/60(opt.)	
	Tool shank		HSK A63/BT/DIN/CAT40		
	Max. tool length	mm	300		
	Max. tool diameter	mm	78		
	Max. tool diameter with adjacent station empty	mm	120		
	Max. tool weight	kg	7		
	Max. loading weight	kg	120	160/240/300	
	Tool changing time(T-T)	sec	1.51(50Hz) 1.25(60Hz)	1.94(50Hz) 1.64(60Hz)	
FEED RATE	X/Y/Z axes rapid feed	m/min	36/36/36		
	A axis max. speed	rpm	16.6		
	C axis max. speed	rpm	90		
ACCURACY	Positioning accuracy	mm	0.005		
	Repeatability	mm	±0.0025		
MACHINE DATA	Length	mm	3015		
	Width	mm	5050		
	Height	mm	3000		
	Floor space	mm	4000x4500		
	Weight	kg	9000		

\*Specifications are subject to change without notice.

● Standard accessories    ○ Optional accessories    NA: No available

Description	MCU 4+1	MCU-5X
Linear scales in X,Y and Z axis	○	●
Rotary scales in A and C axis	●	●
DCM: Dynamic Collision Monitoring	NA	●
Kinematics	○	○
Preparation for 3xHydraulic + 1xPneumatic port	●	●
20 bar coolant through spindle	●	●
Chip conveyor and oil skimmer	●	●
Separate type tank with paper filter	○	○
Oil Mist Collector	○	○
Overhead roof	○	○
Automatic roof	NA	○
Laser tool measurement integrated in table	○	○
Mechanical detachable tool setter	○	NA
20/70 bar CTS with separate tank and paper filter	○	○
TSC: Thermal Spindle Compensation	●	●

### BUFFALO MACHINERY CO., LTD.

56, Lane 318, Desheng Road, Daya District,  
Taichung City 428-46, Taiwan  
P.O. Box 320, Daya, Taichung City, Taiwan  
Tel: +886-4-25 60 37 59 Fax: +886-4-25 60 37 69  
E-mail: info@mail.buffalo.com.tw  
[www.buffalo-machinery.com](http://www.buffalo-machinery.com)



### MICROCUT EUROPE

Ulica hrvatskih branitelja 3  
10430 Samobor CROATIA  
Tel. +385 1 3141 515  
Fax. +385 1 3141 516  
info@microcut-europe.eu  
[www.microcut-europe.eu](http://www.microcut-europe.eu)



# MICROCUT



## MCU Series

Gantry type 5X Vertical Machining Center

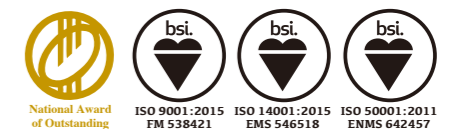

# MCU series

## Gantry Type 5-Axis Machining Center

Brand New Design with Upgrade Performance brings high precision and high-speed 5-Axis machining

**M**CU is designed for complex and multi surface contour machining. The series has working capacity ideal for medium-size workpiece and offers superior performance in all aspects of milling - consistency, accuracy, and power, therefore serving as a critical asset to all industries. The upgraded gantry type design presents compact structure with maximum working area reserved.



### TABLE OPTION

Ø600mm



Ø500x420mm

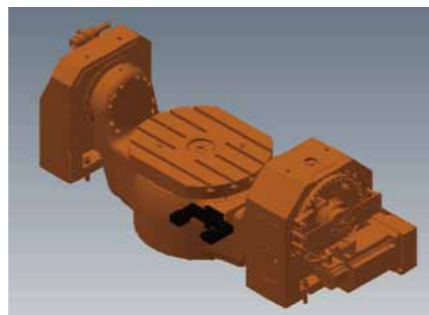

## Gantry structure

The gantry structure offers the best accuracy and rigidity for a 5-axis vertical machining center, allowing high-speed cutting process in complex parts with various materials.

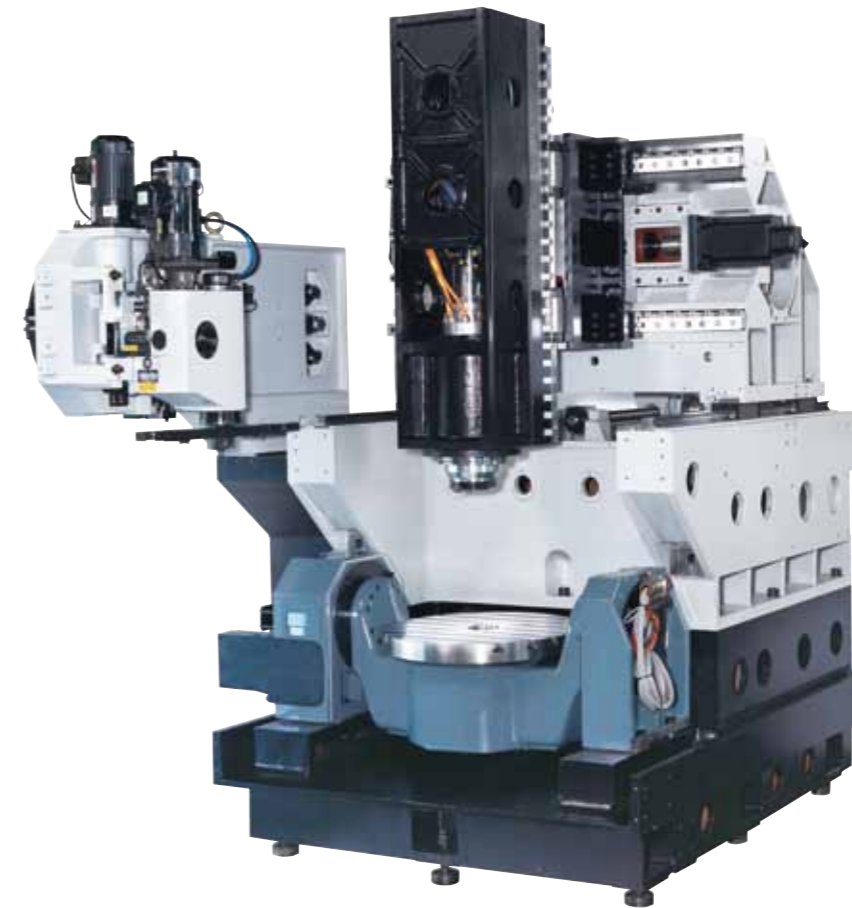

- Spindle moves in linear axis XYZ, ensuring better machining rigidity
- Gantry moves fully supported in all Y-axis travel, for the best accuracy
- All body made of high-quality Meehanite casting, providing optimal damping of machining vibrations and homogeneous thermal behavior
- Excellent accessibility to working area

# Table

# Driving system

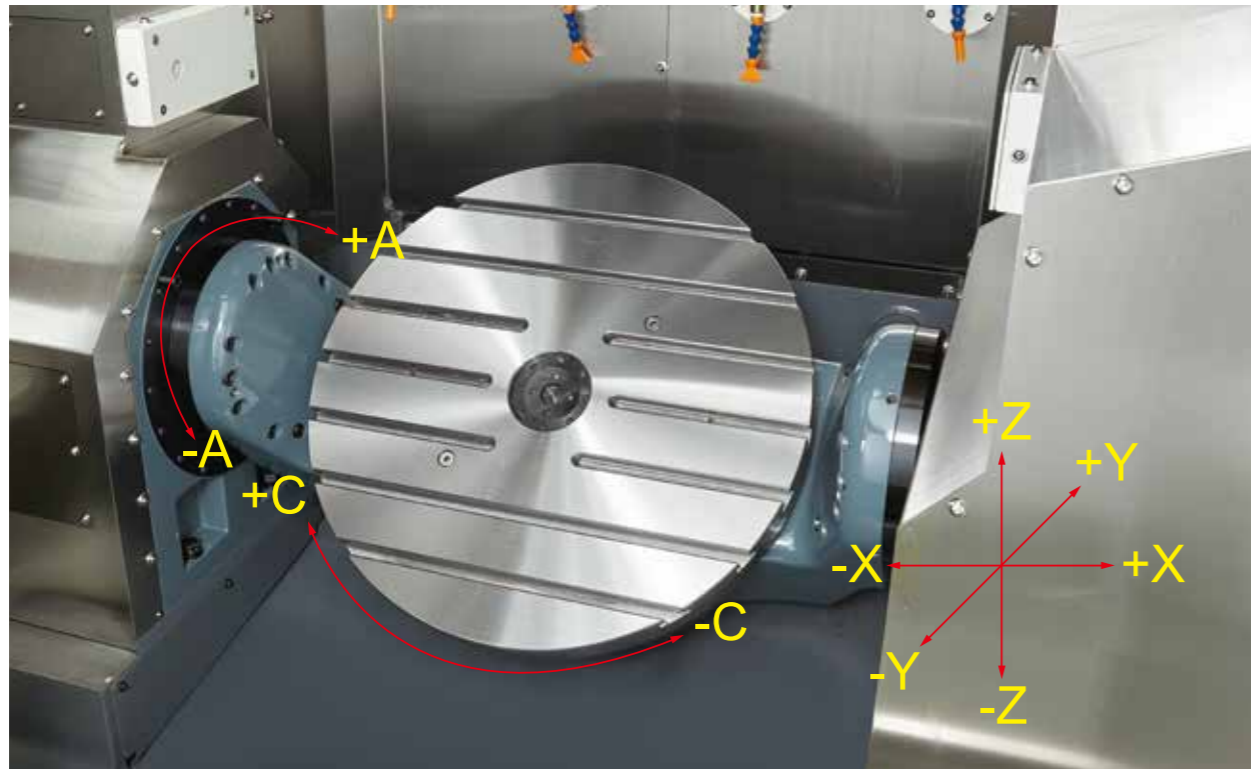
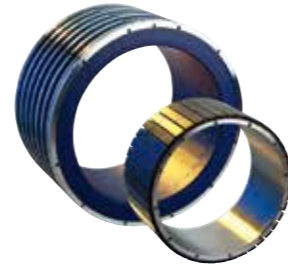

C-axis with torque motor ensures maximum speed and lifetime accuracy

High-repeatability in 4+1x operation

Endure excellent rigidity for roughing operations

A-axis with worm gear for high-torque in tilting operations

Allow best accuracy with maximum table load

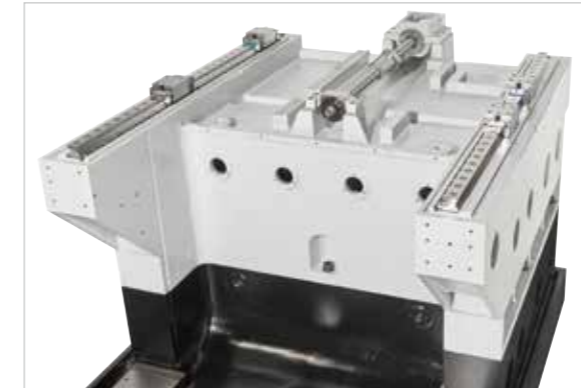

Direct driven servomotors (no belts/gears) endure best dynamic and minimal elasticity in the driving system



Roller type, high rigidity, linear guideways for the best high-feed movement and vibration damping

Pre-loaded double-nut ballscrews minimize backlash and allow high-feed movements (36 m/min)

## Accuracy

### Linear axes

0.1µm resolution absolute linear scales in XYZ axes to compensate the ballscrew thermal growth and ensure the best 3X accuracy



### Rotary axes

±5" accuracy absolute rotary scale feedback for the best rotary axes accuracy



### Linear-Rotary axes relative positioning

CNC embedded compensation functions like Kinematics (Heidenhain), Kinematic chain (Siemens) and Tilted working plane indexing (Fanuc)



## Thermal stability

The heat generated by the spindle motor, the spindle cartridge, and the C-axis torque motor is dissipated by a main cooler

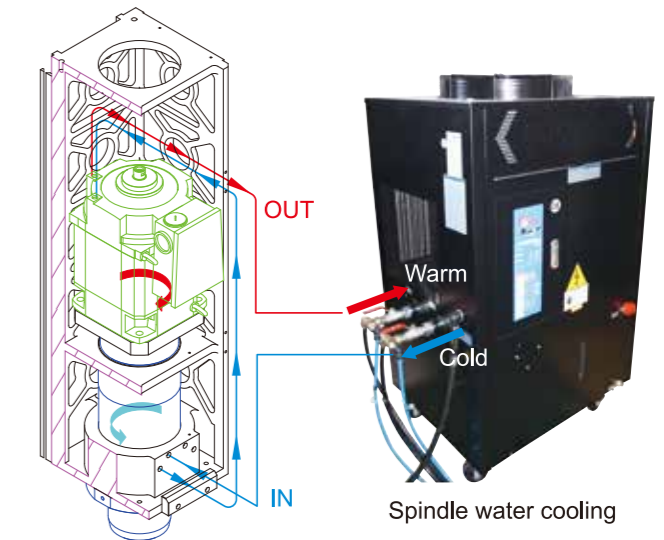

Thermal reduction Design

# Spindle

## • High-torque in-line spindle (#40)

- HEIDENHAIN  
or SIEMENS control
- Double winding motor
  - Water-cooled
  - 15.000 rpm max speed
  - 261 Nm at S6(40%)
  - 35 kW at 1280 rpm

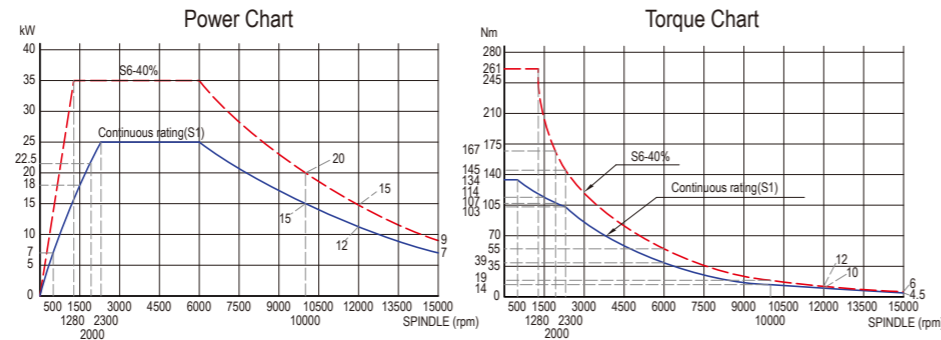

- FANUC control
- Double winding motor
  - Air-cooled
  - 15.000 rpm max speed

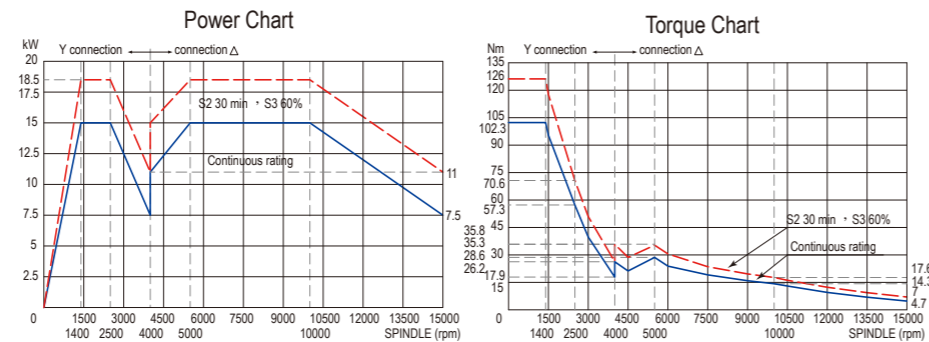

## • High-speed built-in spindle (HSK-A63)

- 18000 rpm  
24000 rpm
- Single winding motor
  - Water-cooled
  - 40 Nm at S6(40%)
  - 25 kW at 6000 rpm

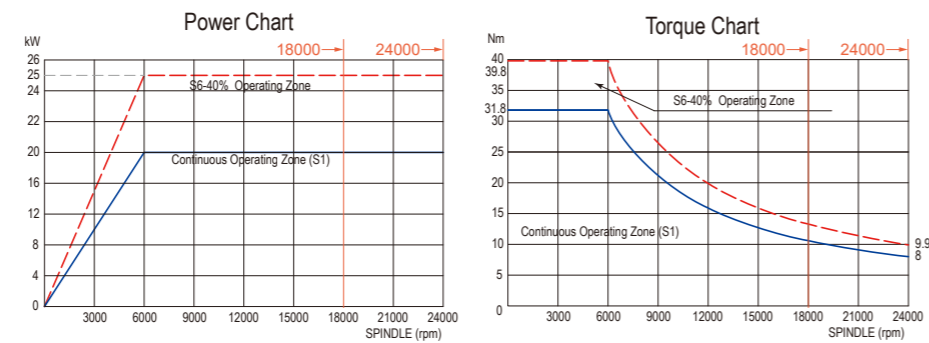

# Chip management

## Standard equipment

- Chain-type chip conveyor with chip bucket.
  - Oil skimmer.
  - Built-in 20 bar through spindle coolant pump.
- Coolant shower, coolant & air spindle nozzle are built for a better chip management

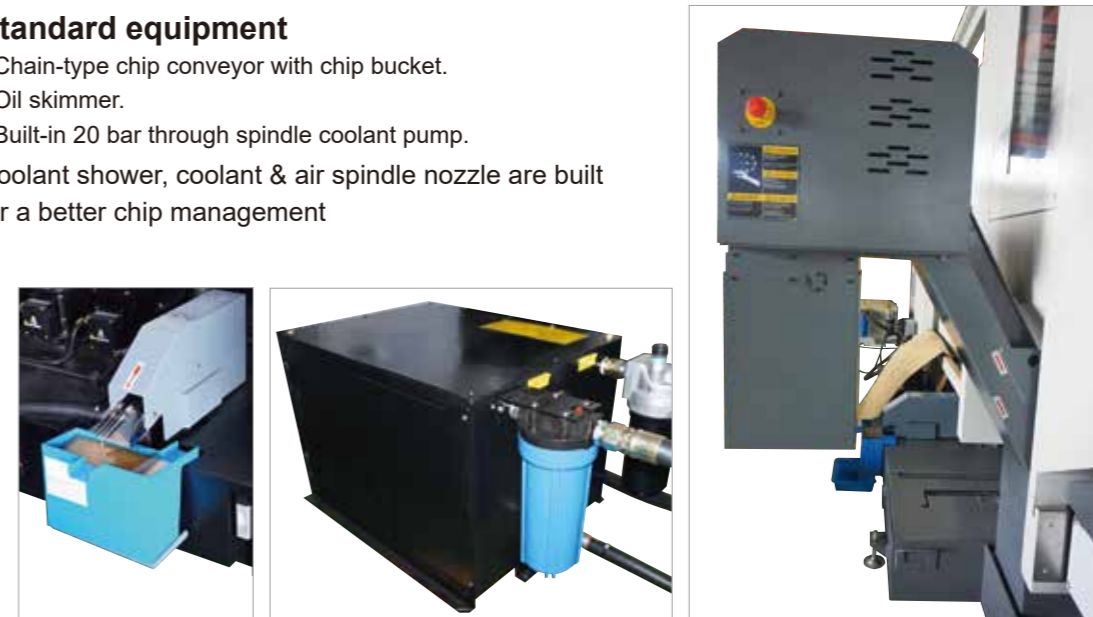

# Tool management



## Tool accessibility

Tools are accessible from the left side of the machine if 48 or 60 tool magazine is chosen

Tools can be easily changed during automatic operation, to avoid idle times between up cutting time

# Premium equipment

# Ergonomy and Maintenance

## Standard

Integrated preparation for **3xhydraulic (80bar) and 1xpneumatic (6 bar)** ports. Clamping and unclamping functions by softkeys in the control panel and/or by M-function.

**Simplifies 5X workpiece clamping.**

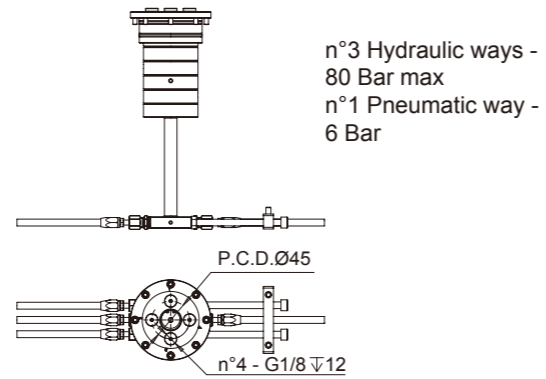

## Optional equipment

Separate type cooling unit including:

- Through spindle 20 bar centrifugal pump or...
- Through spindle 70 bar screw type pump with stepless programmable pressure
- Paper filter • Oil skimmer • Coolant chiller

**Recommended for high aluminum or cast iron material cutting**

## Overhead roof type

Easy loading and unloading of heavy and bulky workpieces by over-head crane



## Automatic roof type

Convenient to open ceiling working area automatically



## Large front door opening

Comfortable access to work area for workpiece preparation and supervision

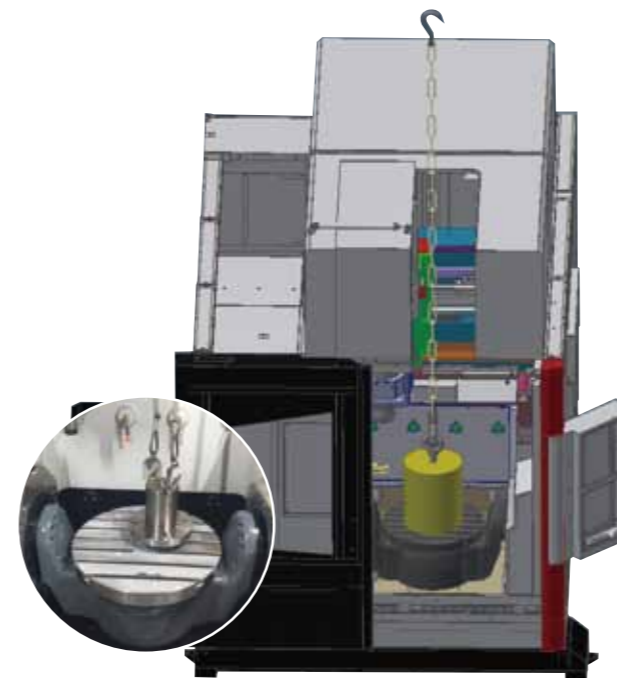

All consumables are located in the same area for easier maintenance activities. Electrical cabinet comes std with air conditioning system.

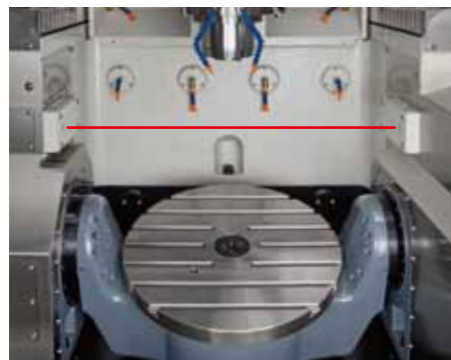

Separate type laser tool setter

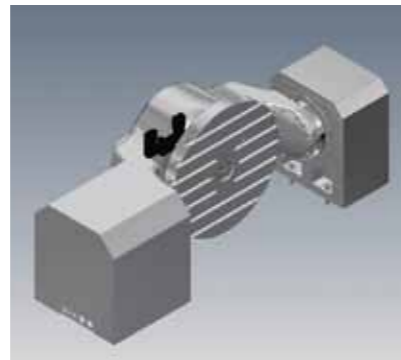

Table-mounted laser tool setter

Laser tool measurement installed for highest accuracy.

- \* Non-contact laser tool setter with separated transmission and receiver units
- \* Table-mounted laser tool setter

**Accurate tool measurement in length, radius and shape**

**In-process tool measurement at working conditions (spindle running at thermal stable conditions)**



**Mechanical tool setter** removable. Used for:

Accurate tool measurement in length, radius and shape

The tool setter is placed when tool setting and removed to avoid interferences during machining



# Controller versions and Panel

# Dimensions and Interference

## 5X



**Heidenhain TNC 640**  
 Controller with Standard:  
 • Kinematics Opt  
 • Tool center point management  
 • Tilted working plane  
 • Dynamic Collision Monitoring: DCM  
 Perfect for 5X operation



**Siemens 840D sl Controller**  
 with Standard:  
 • Kinematics chain  
 • 5X transformation with tool orientation  
 • Swivel the coordinate system  
 • Collision avoidance  
 Perfect for 5X operation

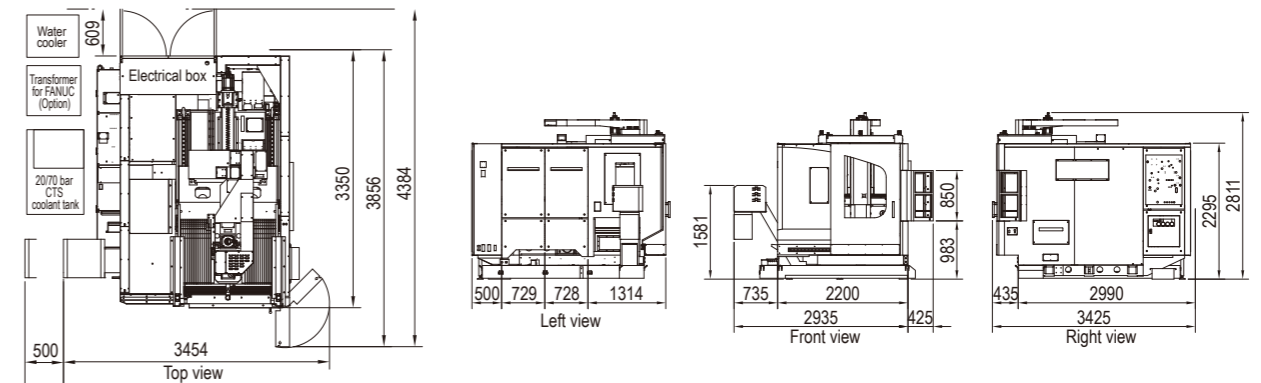

## 4+1 or 3+2 X



**Siemens 828D Controller**  
 with Standard:  
 • Kinematics chain  
 • 5X transformation with tool orientation  
 • Swivel the coordinate system  
 Cost-effective for 4+1X operation



**Fanuc 0iM Controller**  
 with Standard:  
 • Manual Guide i  
 • Tilted working plane indexing  
 Cost-effective for 4+1X operation

Table Ø600mm/Table Ø500x420mm

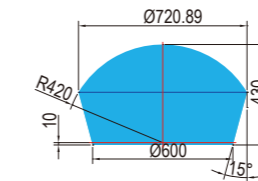

Maximum workpiece

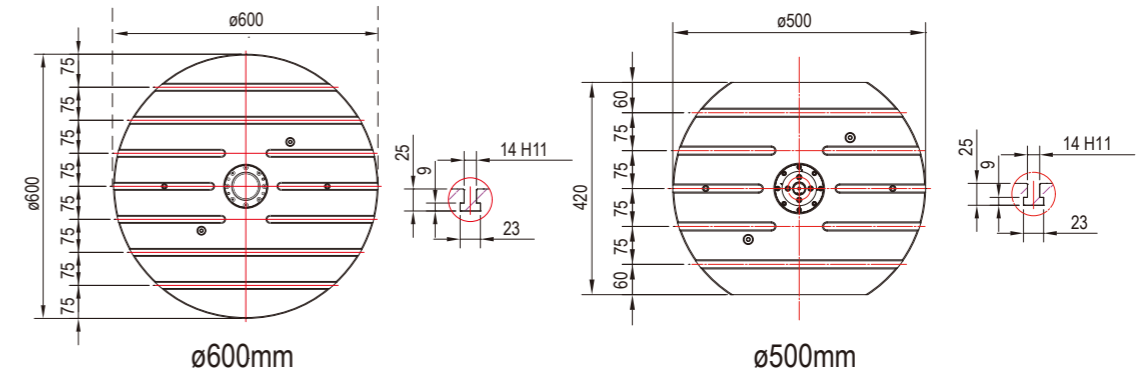

## Flexible controller selection



Pending panel Best ergonomcy for long-lasting CNC operations at the machine



Swivelling panel Best for space requirement

