

MiCROCUT

M Series

Linear Way Vertical Machining Center



National Award
of Outstanding



ISO 9001:2015
FM 538421



ISO 14001:2015
EMS 546518



ISO 50001:2011
ENMS 642457

M Series

Vertical Machining Center

MICROCUT linear way VMC is designed and built to meet the ever-increasing demands for powerful and reliable machines with high efficiency, high accuracy machining performance.

MICROCUT M series uses roller type linear guideways, a high-precision main spindle with thermal expansion stability and a robust and compact structure design with high durability. Depending on machining needs, various travel lengths with great capacity satisfy all demands.



M760

900 x 410 mm Table
XYZ: 760 x 440 x 460 mm
Table load: 350 kg
Spindle: 10000 rpm(std); 12000/15000 rpm(opt)



M800

900 x 520 mm Table
XYZ: 800 x 500 x 500 mm
Table load: 450 kg
Spindle: 10000 rpm(std); 12000/15000 rpm(opt)



M1400

1500 x 700 mm Table
XYZ: 1400 x 730 x 700 mm
Table load: 1500 kg
Spindle: 10000 rpm(std); 12000/15000 rpm(opt)





High-performance solutions for demanding applications



Green Energy Industry



Die & Mold Industry



Automobile Industry



Mechanical Engineering



M1050

1200 x 600 mm Table
XYZ: 1050 x 600 x 600 mm
Table load: 800 kg
Spindle: 10000 rpm(std); 12000/15000 rpm(opt)



M1200

1400 x 710 mm Table
XYZ: 1200 x 730 x 650 mm
Table load: 1000 kg
Spindle: 10000 rpm(std); 12000/15000 rpm(opt)



M1600

1700 x 700 mm Table
XYZ: 1600 x 730 x 700 mm
Table load: 1500 kg
Spindle: 10000 rpm(std); 12000/15000 rpm(opt)



M1600P

1700 x 800 mm Table
XYZ: 1600 x 800 x 800 mm
Table load: 1800 kg
Spindle: 10000 rpm (std); 12000/15000 rpm(opt)

Rigid Construction

The tool magazine is assembled in structural ribs that are directly supported to the ground, thus increasing tool magazine size without compromising column rigidity.

Optimal Rigidity

The major structural component is made of Meehanite cast iron, which is heat treated to relieve stress, and to assure rigidity and accuracy

Rib Enhancement

All casting is reinforced with heavy ribs to resist vibration. The base incorporates a durable ribbed box design for maximum structural loading.

Triangular Support Base

The triangular wide-distance foundation provides solid support for operation.

One-piece Design Headstock

Offering high stability and capacity for heavy duty cutting

Structural Optimization

All structural components and whole machine frame of M series are analyzed by ANSYS mechanical system and Finite Element Method (FEM) to ensure structural optimization.

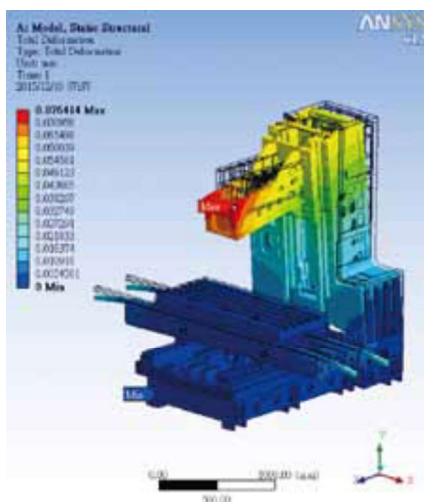

M1050

Motion Control

1 Ballscrew

C3 Class Pretensioned Ballscrew

Class C3 ballscrews are pretensioned on each axis to reduce heat deformation for high accuracy and repeatability.

Direct-coupled Servo Ballscrew Motor

Direct-coupled servo motor can enhance positioning accuracy and provide better contouring and threading

2 Guideway

High Precision Linear Guideways

Installed for all axes to ensure high load carrying capacity and rigidity with high running and positional accuracy as well as low friction.

2

3



M1600

Ball Type linear Guideway

M760

The recirculation ball guideways for each axis are preloaded to provide zero clearance between the moving surfaces. This increases rigidity in all directions while providing higher accuracy and reliability

Roller Type Linear Guideway

M800/ M1050/ M1200/ M1400/ M1600/ M1600P

High rigidity steel on roller guideway provides high durability. Roller guideway on the three axes enables a fast feed rate of 30 m/min, ensuring smooth movement and accuracy.

4-guideway base to support saddle

M1400/M1600/M1600P

The bigger models of M series mount 4 linear guideways in the Y axis to ensure the maximum rigidity with high loading capacity



Spindle

M series is built with innovative machine concepts by using a wide range of high-performance spindles to present consistent precision performance and dynamic machining for various application.

Extensive options of spindle types and motor configuration are provided to meet industrial demands. The higher horsepower motors are also available to optimize the strength of machine for ultimate machining performance.



- **Belt Drive spindle**

The standard 10,000 rpm belt drive spindle with ISO 40 taper.



- **In-line spindle (Opt)**

The powerful direct drive of 12,000 and 15,000 rpm spindles with ISO 40 taper ensure high machining performances.

Spindle Dynamic Balancing

The online dynamic balancing instrument offers calibration for spindle displacement, speed and acceleration of full speed range

High rigidity Spindle

With preloaded angular-contact bearings throughout and with a large spacer between front bearings to improve radial thrust capacity. Cartridge spindle design makes maintenance easy.



Spindle oil cooler (opt)

All machines are available to equip with spindle oil cooler to prevent thermal expansion effects and thermal deformation, allowing high accuracy machining, perfect finish and long lifetime of spindle as well.

Tool Management

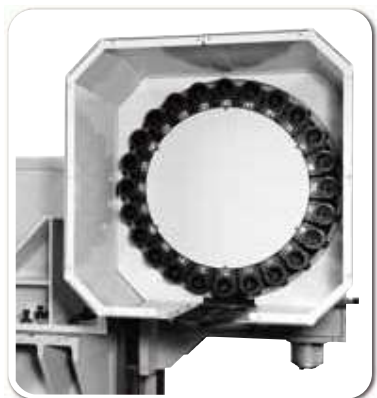

24T Arm type ATC



40T chain type ATC

Fast and Reliable

Arm type ATC

Providing stable and quicker tool selection

It is activated by electric motor and driven by cam mechanism. The bi-direction tool selection is controlled by PLC software for quicker tool selection to reduce non-cutting time.

Standard

Random arm type 24 Tools - all series

Optional

Carrousel type 16 Tools - M760

Random drum type 30 Tools - all series

Random chain type 40 Tools - M1050, M1200, M1400, M1600, M1600P

40 tool chain type magazine is accessible from back of machine for easy loading and unloading of tools while machine automatic operation.



Tool selection panel

Coolant Through Spindle (opt)

Coolant through spindle uses high pressure pump to supply coolant through tool, cooling the cutting edge directly. This clears chips during deep-hole and tapping, increases tool life and allows higher cutting speeds.

CTS system options:

- CTS 20 bar built-in type
- CTS 20 bar separate type
- CTS 20 bar separate type with paper filter
- CTS 70 bar programmable separate type with paper filter



CTS 20 bar built-in type



CTS 20 bar separate type



CTS 20 bar separate type with paper filter

Auxiliary Coolant Filter

Individual CTS tank is supplied with a re-usable 25-micron iron filter. Built-in system provides 25-micron filter. Both filters take away contamination and particles from the coolant before coolant is recycled through the coolant pump.

Chip Removal

- Efficient Free-flow enclosure guard design
- Efficient chip conveyor carries out chips to save operation time
- Drainage outlet design
- Multiple chip flush solution offers easy chip clean
 - Rear wash down with high pressure pumps(opt)
 - Spindle with coolant nozzle



Multiple chip flush solution



Free-flow enclosure guard design



Drainage outlet & Chip conveyor



Spindle with coolant nozzle



Coolant gun

Control



FANUC 0iMF CONTROL

- High reliable
- High-speed, high-precision and high-quality machining with AI contour control
- Machining condition selection function
- Enriched basic functions: rigid tapping, tool life management
- Advanced digital servo technology
- User friendly operation: Program editing, memory card, data server

Excellent Operation

Integration operation & programming guidance with extremely simplified operations

FANUC MANUAL GUIDE 0i (std)

Integrated operation guidance for NC program

FANUC MANUAL GUIDE i (opt)

- Programming guidance
- With extremely simplified operations



MITSUBISHI M80H CONTROL

- Panel-in type, a control unit with integrated display
- Windows-less display provides easy operability
- A touchscreen display as standard
- Smartphone-like intuitive touch operation
- View 3D model at any desired size for 3D graphic check, supporting both turning and milling



FAGOR 8065/8055 CONTROL

- High speed machining, large look-ahead buffer and a high speed block processing time
- Graphically assisted set up user interfaces
- Preparation help on tool management
- Various programming languages provide improved operator ease & efficiency:
 - Wide range of ICON conversational cycles
 - ISO code languages



HEIDENHAIN iTNC 620 CONTROL

- Minimize setup times
- Graphic support in any situation
- Straight forward function keys for complex contours
- Programming contours unconventionally
- Field-proven cycles for recurring operations
- Smart T.NC the alternative operating mode
- Program off line
- Fast data transfer
- The iTNC programming station
- Setup, presetting and measuring with touch trigger



SIEMENS SINUMERIK 828D CONTROL

- Easy data exchange thanks to USB, CF and Ethernet interfaces on the panel
- ShopMill machining step programming
- SINUMERIK CNC programming language with high-level elements and program guide
- Online ISO dialect interpreter: maximum CNC program compatibility
- Advanced Surface: Innovative, high-performance CNC functions
- Animated Elements: Optimized operator guidance
- Easy input of pictographic languages directly via the CNC keyboard
- Easy Message: Integrated mobile radio modem for optimum process monitoring via mobile telephone.

Layout Dimension

M760

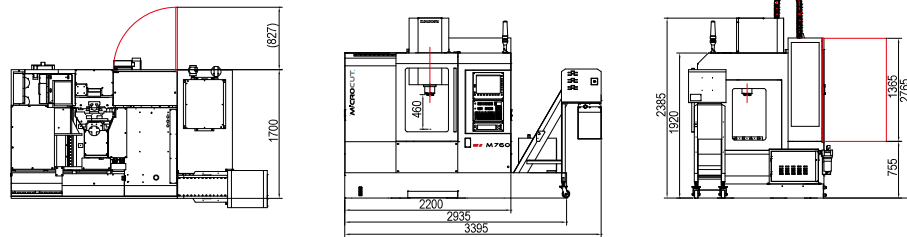

M800

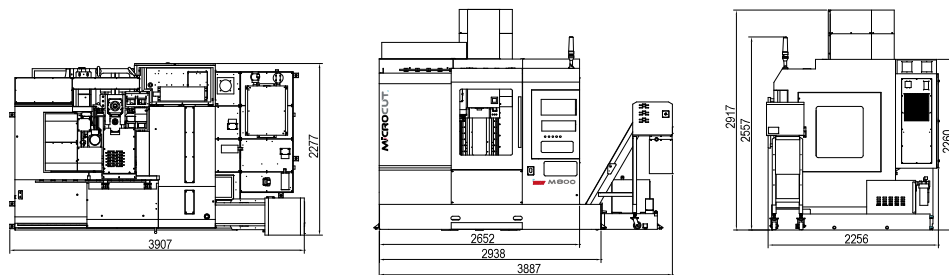

M1050

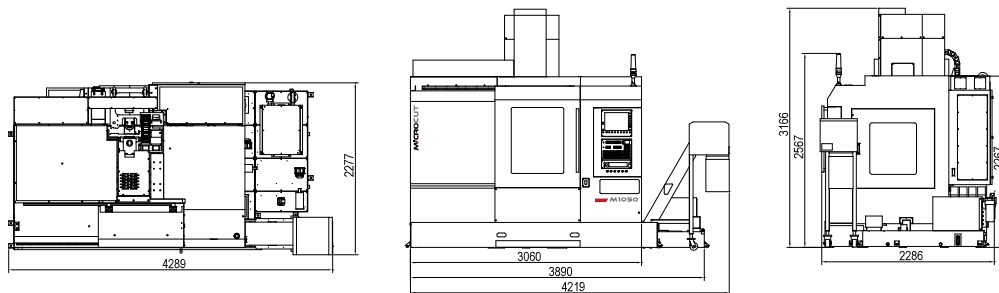

M1200

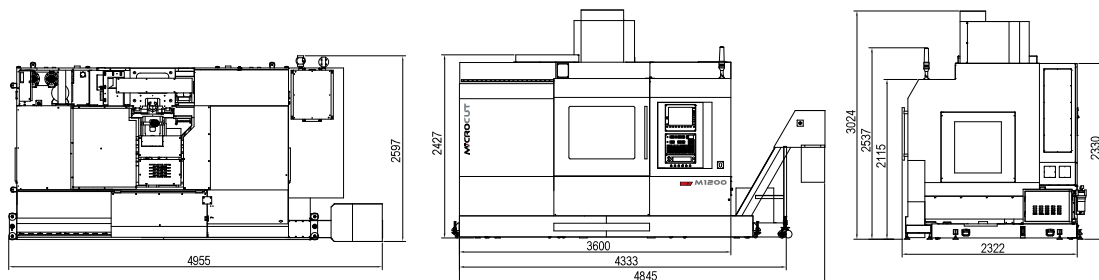



M1400

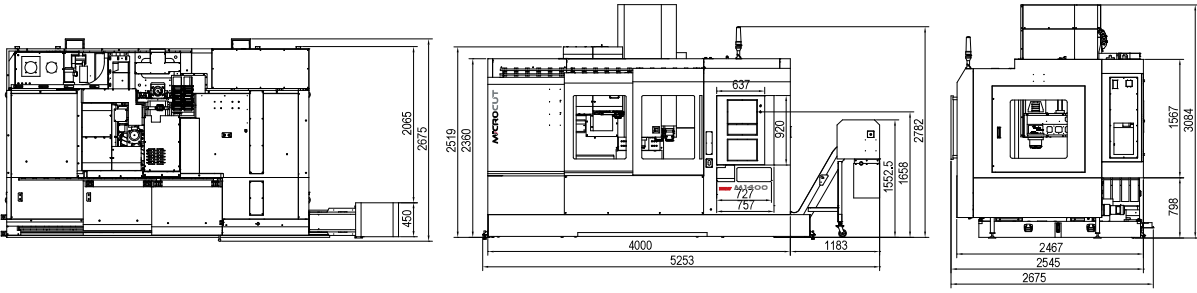

M1600

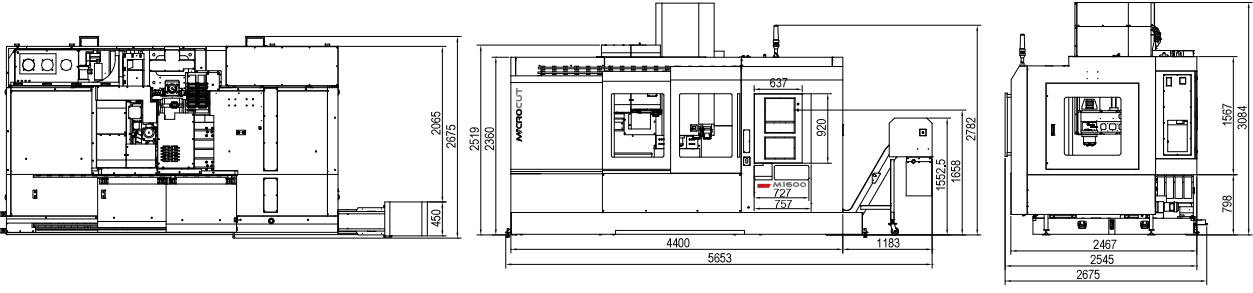

M1600P

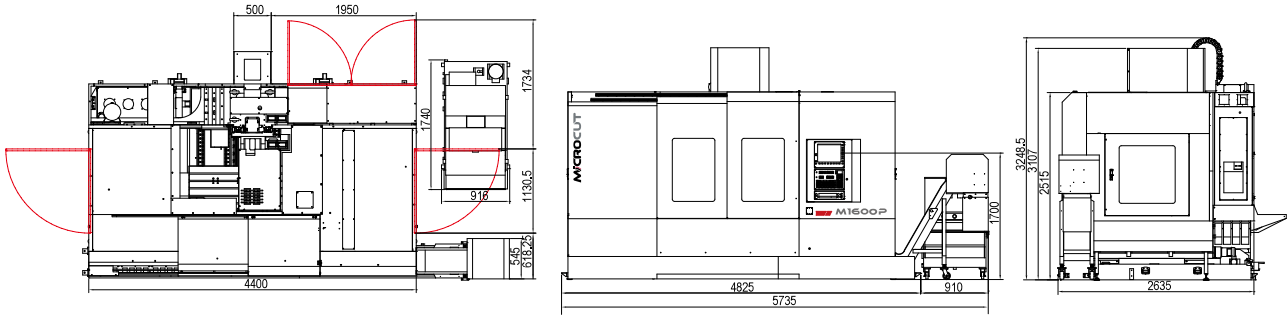

Spindle Power & Torque Chart

Controller Spindle / Motor Availability Table

ISO40 Taper		Heidenhain 620		Siemens 828D	
		STD Power	Upgrade Power	STD Power	Upgrade Power
M760	10000 rpm belt-driven		QAN200U 10/14 kW 63.7/89.1 Nm	1PH8105 7/10.5 kW 44.5/66.8 Nm	1PH8107 10.5/15.8 kW 63/94.5 Nm
	12000 rpm in-line		QAN200UH 10/14 kW 63.7/89.1 Nm		
	15000 rpm in-line			1PH8105 7.5/11.3 kW 53.5/80.2 Nm	1PH8107 8.5/12.8 kW 42/80 Nm
M800	10000 rpm belt-driven		QAN200U 10/14 kW 63.7/89.1 Nm	1PH8105 7/10.5 kW 44.5/66.8 Nm	1PH8107 10.5/15.8 kW 63/94.5 Nm
	12000 rpm in-line		QAN200UH 10/14 kW 63.7/89.1 Nm		
	15000 rpm in-line			1PH8105 7.5/11.3 kW 53.5/80.2 Nm	1PH8107 8.5/12.8 kW 42/80 Nm
M1050 M1200 M1400 M1600 M1600P	10000 rpm belt-driven	QAN200U 10/14 kW 63.7/89.1 Nm	1PH8133 20/30 kW 133.7/200.6 Nm	1PH8107 10.5/15.8 kW 63/94.5 Nm	1PH8133 15/22.5 kW 126/189.1 Nm
	12000 rpm in-line	QAN200UH 10/14 kW 63.7/89.1 Nm			1PH8107 8.5/12.8 kW 63/91.7 Nm
	15000 rpm in-line				

ISO50 Taper		Heidenhain 620		Siemens 828D	
		STD Power	Upgrade Power	STD Power	Upgrade Power
M1400 M1600 M1600P	8000 rpm belt+gearbox	QAN260M 15/25 kW	QAN260L 20/30 kW	1PH8133 15/22.5 kW	1PH8133 20/30 kW
	Ratio 1:1	95.5/159.2Nm	127/191Nm	126/189 Nm	133.7/200.6 Nm
	Ratio 1:4	382/636.7 Nm	509/768 Nm	504/756 Nm	534.8/802.4 Nm



Fanuc OiM		Fagor 8055/8065		Mitsubishi M80H	
STD Power	Upgrade Power	STD Power	Upgrade Power	STD Power	Upgrade Power
Beta iI8 7.5/11kW 47.8/70 Nm		FM7-A075 7.5/11 kW 47.8/71.5 Nm		SJ-DG11 7.5/11 kW 47.7/70 Nm	
Alpha iT8 7.5/11kW 47.8/70 Nm		FM7-D075 7.5/11 kW 47.7/70 Nm		SJ-VS11 7.5/11 kW 47.7/70 Nm	
Alpha iT8 9/11 kW 57.3/70 Nm					
Beta iI8 7.5/11 kW 47.8/70 Nm	Beta iI12 11/15 kW 70/95.5 Nm	FM7-A075 7.5/11 kW 47.8/71.5 Nm	FM7-A110 11/15.5 kW 70/100.4 Nm	SJ-DG11 7.5/11 kW 47.7/70 Nm	SJ-V22 11/15 kW 70/95.5 Nm
Alpha iT8 7.5/11 kW 47.8/70 Nm	Alpha iT12 11/15 kW 70/95.5 Nm	FM7-D075 7.5/11 kW 47.7/70 Nm	FM7-D110 11/15.5 kW 70/98.7 Nm	SJ-VS11 7.5/11 kW 47.7/70 Nm	SJ-VKS15 11/15 kW 70/95.5 Nm
Alpha iT8 9/11 kW 57.3/70 Nm			1PH8107 8.5/12.8 kW 63/95.5 Nm		SJ-VKS30 11(15)/18.5 kW 70/95.5 Nm
Alpha iI12 11/15 kW 70/95.5 Nm	Alpha iT15 15/18.5 kW 102/126 Nm	FM7-A110 11/15.5 kW 70/100.4 Nm	FM7-A150 15/22 kW 95.5/143.9 Nm	SJ-V22 11/15 kW 70/95.5 Nm	SJ-V18.5 11/15 kW 95.5/118 Nm
Alpha iT12 11/15 kW 70/95.5 Nm		FM7-D110 11/15.5 kW 70/98.7 Nm	FM7-D185 18.5/32 kW 117.8/165.5 Nm	SJ-VKS15 11/15 kW 70/95.5 Nm	SJ-VKS30 11(15)/18.5 kW 75/95.5 Nm
Alpha iT15 15/18.5 kW 102/126 Nm		1PH8107 8.5/12.8 kW 63/95.5 Nm	1PH8133 20/30 kW 133.7/200.6 Nm		

Fanuc OiM		Fagor 8055/8065		Mitsubishi M80H	
STD Power	Upgrade Power	STD Power	Upgrade Power	STD Power	Upgrade Power
Alpha iI15 15/18.5 kW	Alpha iI18 18.5/22 kW	FM7-A150 15/22 kW	FM7-A185 18.5/26 kW	SJ-D18.5 15/18.5 kW	SJ-D22 18.5/22 kW
95.5/117.7 Nm	118/140 Nm	95.5/143.9 Nm	117.8/165 Nm	95.5/118 Nm	118/140 Nm
382/470.8 Nm	472/560 Nm	382/575.6 Nm	471.2/660 Nm	382/472 Nm	472/560 Nm

Power & Torque Chart

ISO40 spindle motor

Heidenhain QAN200U/QAN200UH 10/14 kW

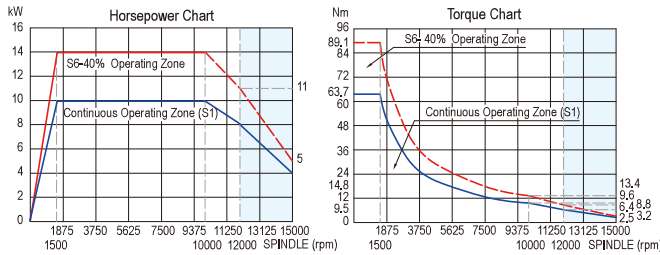

Siemens 1PH8133 20/30 kW

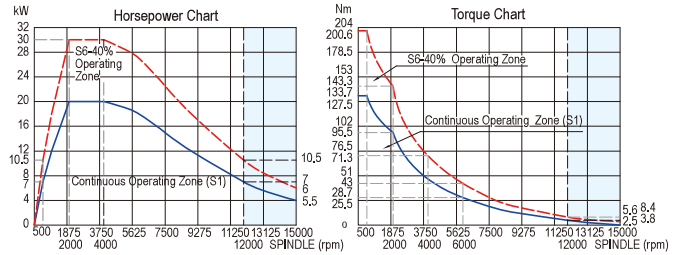

Siemens 1PH8133 15/22.5 kW

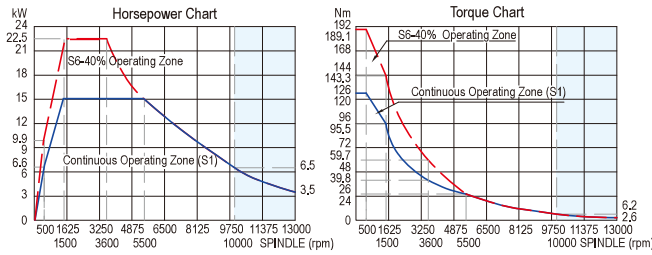

Siemens 1PH8105 7/10.5 kW

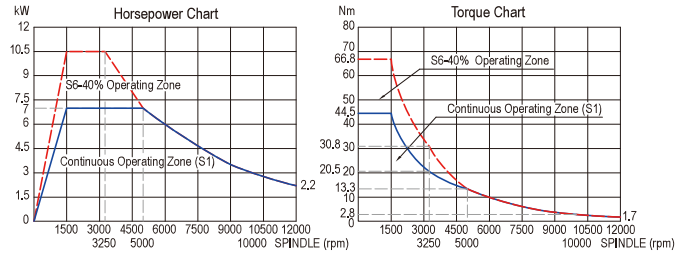

Siemens 1PH8105 7.5/11.3 kW

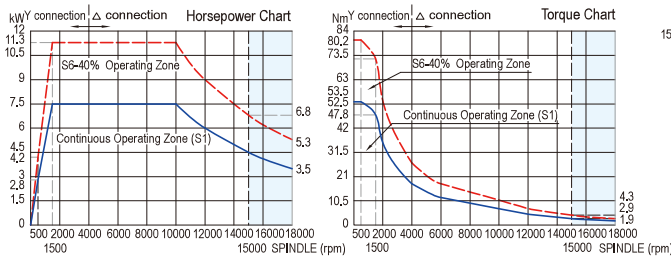

Siemens 1PH8107 10.5/15.8 kW

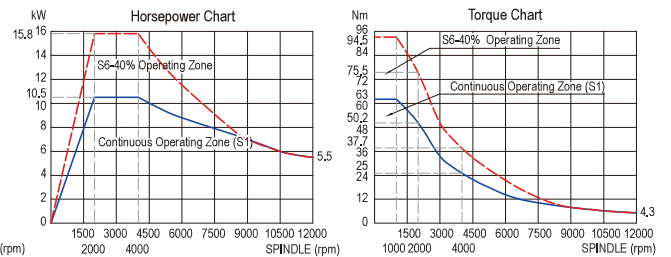

Siemens 1PH8107 8.5/12.8 kW

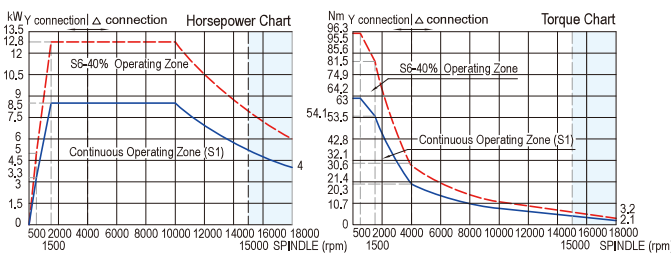

Fanuc beta i18/alpha i18 7.5/11 kW

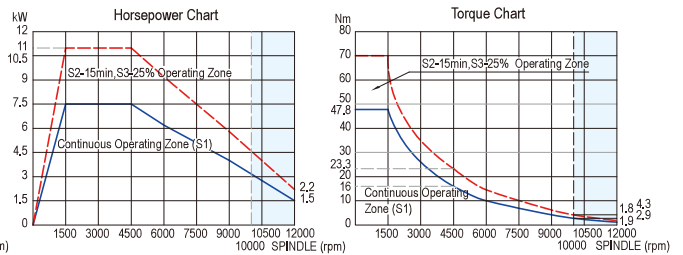



Fanuc oilT12 11/15 kW

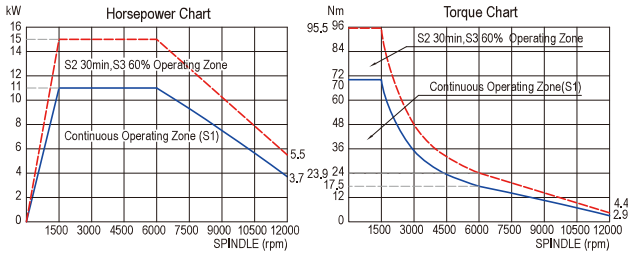

Fanuc oilT15 15/18 kW

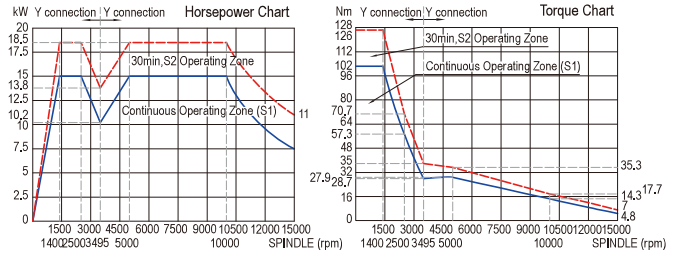

Fagor FM7-A075 7.5/11 kW

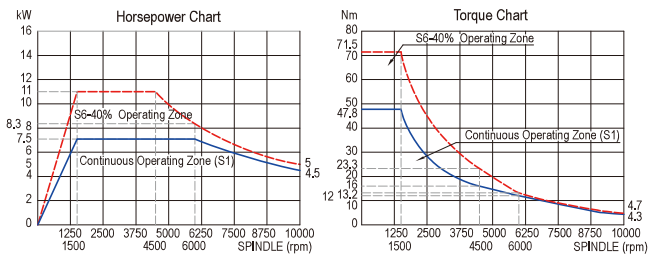

Fagor FM7-D075 7.5/11 kW

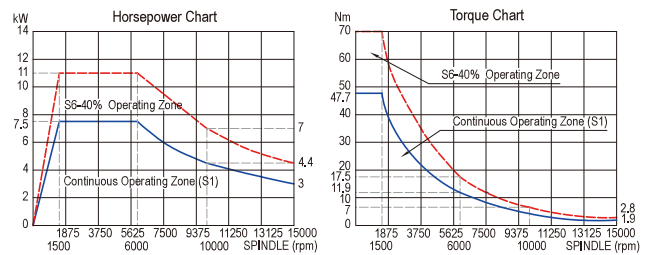

Fagor FM7-A110 11/15 kW

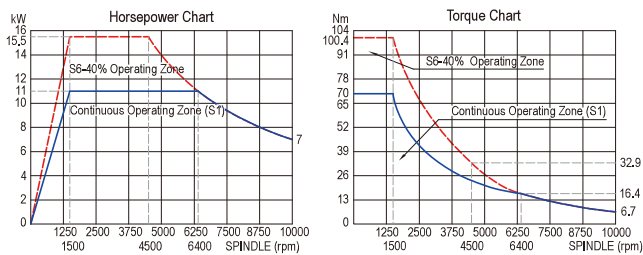

Fagor FM7-D110 11/15 kW

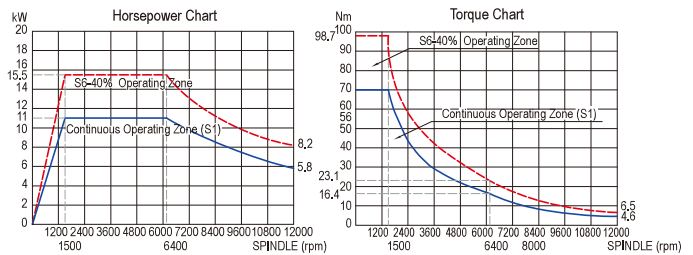

Fagor FM7-A150 15/22 kW

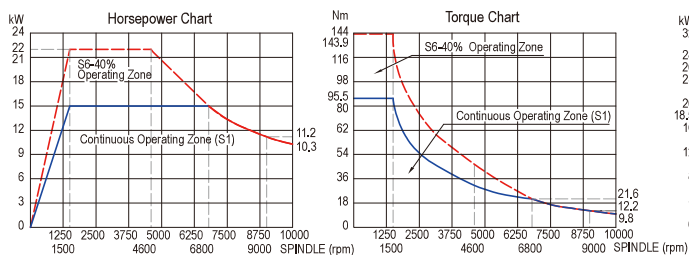

Fagor FM7-D185 18.5/32 kW

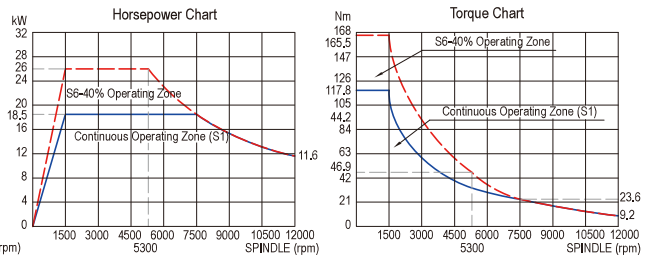

Power & Torque Chart

Fagor FM7-D185 18.5/32 kW

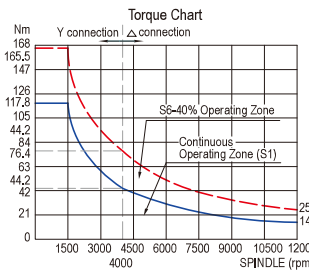
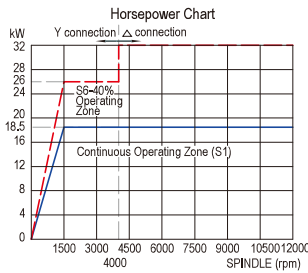

Mitsubishi SJ-DG11 7.5/11 kW

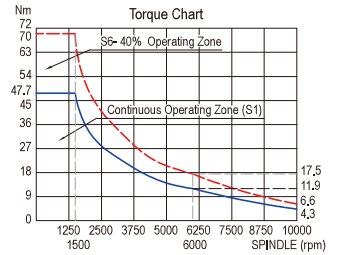
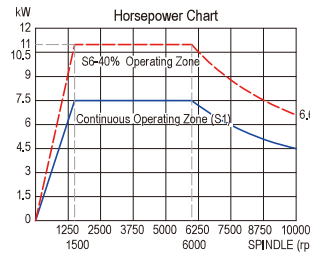

Mitsubishi SJ-VS11 7.5/11 kW

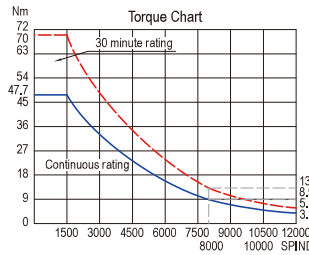
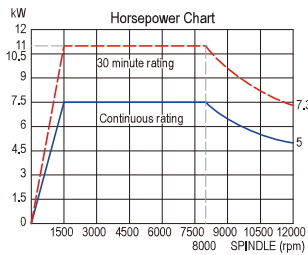

Mitsubishi SJ-V22 11/15 kW

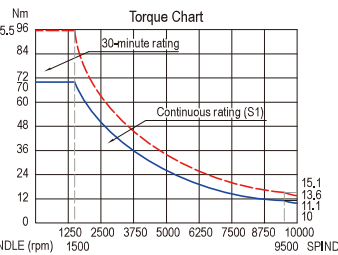
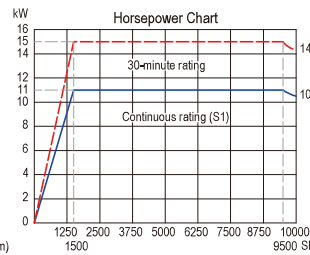

Mitsubishi SJ-VKS15 11/15 kW

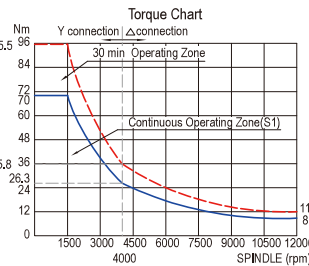
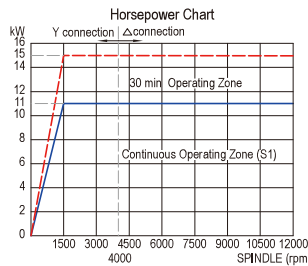

Mitsubishi SJ-VKS30 11(15)/18 kW

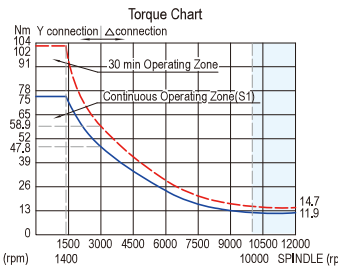
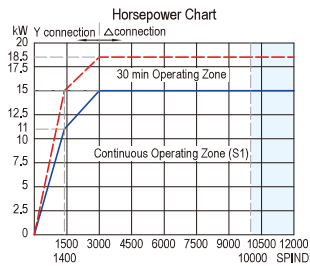

ISO50 spindle motor

Heidenhain QAN 260M 15/25 kW

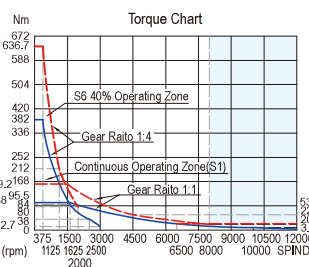
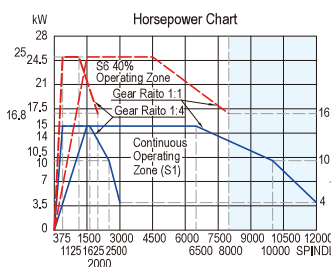

Heidenhain QAN 260L 20/30 kW

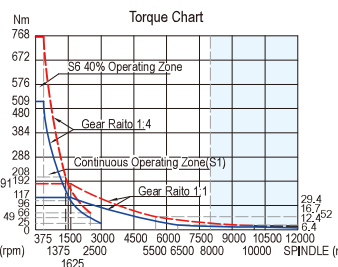
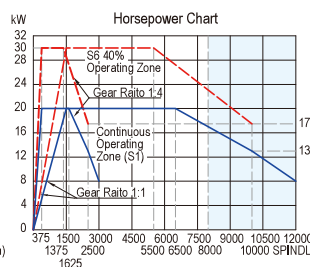



ISO50 spindle motor

Siemens 1PH8133 15/22.5 kW

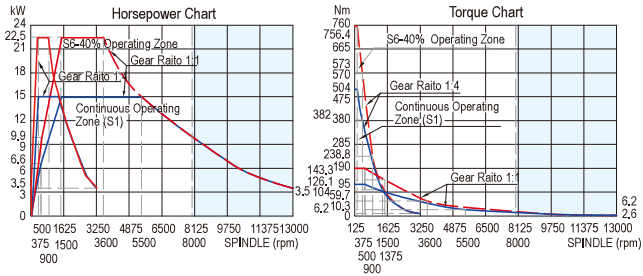

Siemens 1PH8133 20/30 kW

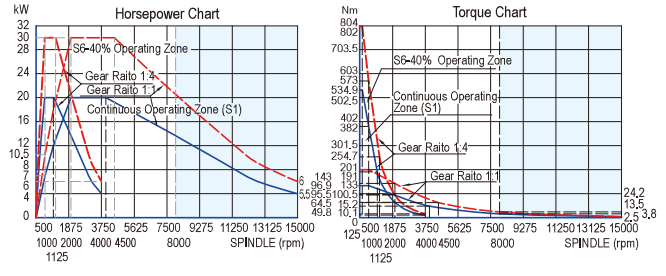

Fanuc oil15 15/18 kW

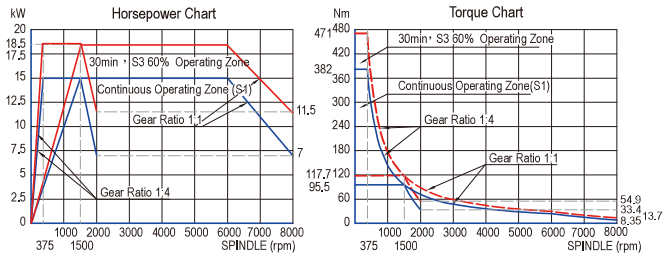

Fanuc oil18 18.5/22 kW

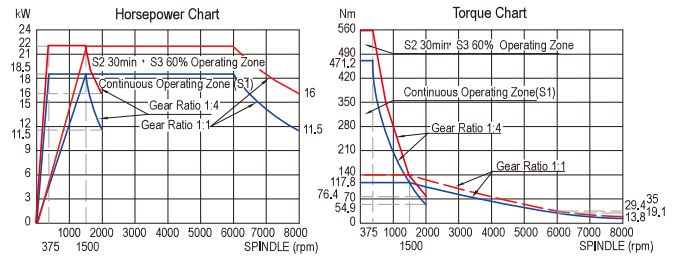

Fagor FM7-A150 15/22 kW

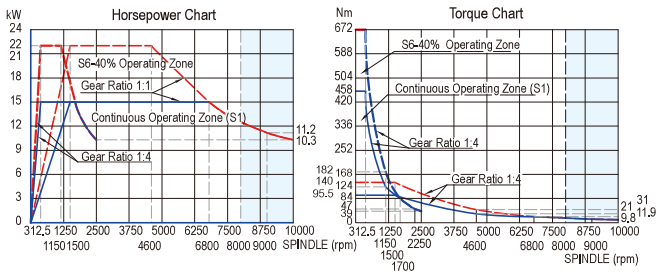

Fagor FM7-A185 18.5/26 kW

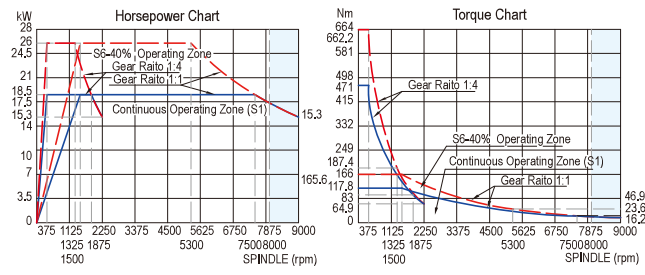

Mitsubishi SJ-D18.5 15/18.5 kW

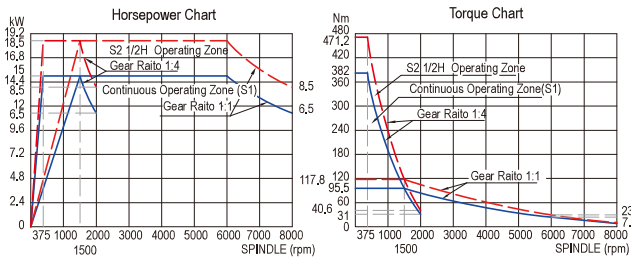

Mitsubishi SJ-D22 18.5/22 kW

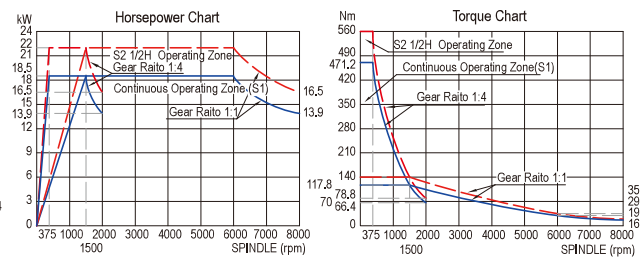

Technical data

Table	Unit	M760	M800	M1050
Table size	mm	900 x 410	900 x 520	1200 x 600
Table loading	kg	350	450	800
Traval				
X axis	mm	760	800	1050
Y axis	mm	440	500	600
Z axis	mm	460	500	600
Spindle (std)				
Driven system			Belt-driven	
Spindle speed	rpm		10000	
Interface			ISO40	
Spindle (opt)				
Driven system				
Spindle speed	rpm			
Interface				
Axes feed rate				
X/Y/Z rapid feed	m/min	30/30/30	30/30/30	30/30/30
Guideway				
X/Y/Z guideway type	mm	Linear / 35 (Ball)	Linear / 35(Roller)	Linear / 45 (Roller)
Number of guides in Y axis		2	2	2
Accuracy (ISO 10791-4)				
Positioning accuracy	mm	0.01	0.01	0.01
Repeatability	mm	0.01	0.01	0.01
Automatic Tool Changer				
ATC type		Arm type 24T(std) / 30T(opt) Carrousel type 16T(opt)	Arm type 24T(std) / 30T(opt)	Arm type 24T(std) / 30T(opt)
Tool taper		BT / CAT / DIN 40	BT/CAT/DIN 40	BT/CAT/DIN 40
Tool changing time (T-T)	sec	1.94(50Hz) /1.64(60Hz)	1.94(50Hz) /1.64(60Hz)	1.94(50Hz) /1.64(60Hz)
Max. tool dia.	mm	ø75	ø75	ø75
Max. tool dia. with next tool empty	mm	ø125	ø125	ø125
Max. tool length	mm	300	300	300
Max. tool weight	kg	7	7	7
Machine size				
Length x Width x Height (w/ conveyor)	mm	3395x1910x2720	3950x2300x2950	4300x2300x3200
Weight	kg	4300	5750	7000
Floor space (With chip conveyor)	mm	3395 x 1910	3950 x 2300	4300 x 2300

Specification are subject to change without notice.

Standard Accessories

- Belt drive spindle 10000 rpm
- Arm type 24T tool capacity - M760, M800, M1050, M1200, M1400, M1600
- Arm type 30T tool capacity - M1600P
- Roof with door opening for overhead crane
- C3 class precision ground ballscrew
- Linear guideway
- Automatic lubrication with low lubrication fault
- Coolant system
- Telescopic guideway covers
- Low voltage circuit system
- Chain type chip conveyor
- Rear wash down device
- CE standard electrical control system
- Fully enclosure with slide door
- Rigid tapping function
- EMC and Safety module
- CE-marking declaration
- Heat exchanger
- 4th axis preparation



	M1200	M1400	M1600	M1600P
	1400 x 710	1500 x 700	1700 x 700	1700 x 800
	1000	1500	1500	1800
	1200	1400	1600	1600
	730	730	730	800
	650	700	700	800
	Gear box / Belt-driven			
	8000(opt) /10000(std)			
	BT50 (8000)/ISO40(10000)			
	In-line driven			
	12000(opt) /15000(opt)			
	ISO40			
	30/30/30	30/30/30	30/30/30	30/30/30
r)	Linear / 45(Roller)	Linear / 45(Roller)	Linear / 45(Roller)	Linear / 45(Roller)
	2	4	4	4
	0.01	0.01	0.01	0.01
	0.01	0.01	0.01	0.01
T(opt)	Arm type 24T(std) / 30T(opt)	Arm type 24T(std) / 30T(opt)	Arm type 24T(std) / 30T(opt)	Arm type 30T(std) / 40T(opt)
	BT/CAT/DIN 40	BT/CAT/DIN 40	BT/CAT/DIN 40	BT/CAT/DIN 40
tz)	1.94(50Hz) /1.64(60Hz)	1.94(50Hz) /1.64(60Hz)	1.94(50Hz) /1.64(60Hz)	1.94(50Hz) /1.64(60Hz)
	ø75	ø75	ø75	ø75
	ø125	ø125	ø125	ø125
	300	300	300	300
	7	7	7	8
	4600x2620x3050	5253x2675x2800	5653x2675x2800	5735x3050x3115
	8200	9500	9800	10500
	4600 x 2620	5253 x 2675	5653x2675	5735x3050

Optional Accessories

- In-line spindle 12000/15000 rpm
- Chip bucket
- Air conditioner
- Coolant gun
- Oil skimmer
- 4th axis
- CTS 20 bar built-in type
- CTS 20 bar separate type
- CTS 20 bar separate type with paper filter
- CTS 70 bar programmable separate type with paper filter
- Tool setting probe
- Workpiece probe
- Three axes with linear scales
- Carrousel type 16T tool capacity - M760
- Random drum type 30T tool capacity - M760, M800, M1050, M1200, M1400, M1600
- Random chain type 40T tool capacity - M1050, M1200, M1400, M1600, M1600P
- 3-color lamp of cycle finish
- Transformer for 380V~440V



BUFFALO MACHINERY CO., LTD.

56, Lane 318, Desheng Road, Daya District,
 Taichung City 428-46, Taiwan
 P.O. Box 320, Daya, Taichung City, Taiwan
 Tel: +886-4-25 60 37 59 Fax: +886-4-25 60 37 69
 E-mail: info@mail.buffalo.com.tw
www.buffalo-machinery.com



MICROCUT EUROPE

Ulica hrvatskih branitelja 3
 10430 Samobor CROATIA
 Tel. +385 1 3141 515
 Fax. +385 1 3141 516
info@microcut-europe.eu
www.microcut-europe.eu

