



SH210/260/310/410

CNC Gear Hobbing Machine SH Series



SH210/260/310/410 'Cassiopeia'

For Your Future

High Speed, High Accuracy, High Productivity

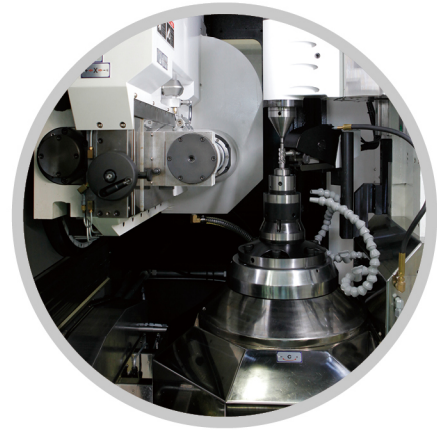

SH210/SH260/SH310

- Max. Workpiece Dia. $\varnothing 210/\varnothing 260/\varnothing 310$
- Max. Workpiece Module M6
- Max. Hob Speed 2,000 rpm
- Max. Table Speed 300 rpm
- X,Z-Axis Rapid 12m/min
- Spindle Motor Power 12kW



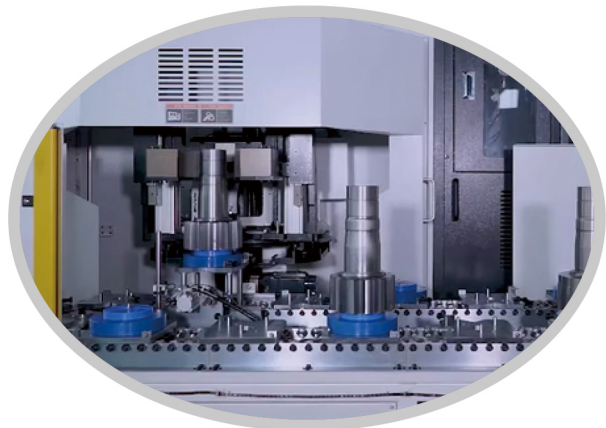

SH410

- Max. Workpiece Dia. Ø410
- Max. Workpiece Module M8
- Max. Hob Speed 1,000 rpm
- Max. Table Speed 200 rpm
- X,Z-Axis Rapid 12m/min
- Spindle Motor Power 15kW



Features of SH Series

- ▶ By applying Wide Slide way in the Bed and Column, supply the High Cutting resistance
- ▶ Realization of Zero Backlash by applying High torque Direct-Drive Motor on C-axis
- ▶ Wet and Dry hobbing process on the same Machine
- ▶ Provides an easy and user-friendly dialogue programming environment



SH210/260/310/410 'Cassiopeia'

For Your Future

Features of Sub Assembly

High rigidity hob head

- ▶ By applying Linear roller bearing to Y-axis and arbor support, it guarantees high precision while heavy cutting and enables tangential cutting
- ▶ By applying Dual Contact Hob arbor, maintain the high spindle rigidity while heavy cutting
- ▶ Quick and easy hob setting is possible with the Hob presetter

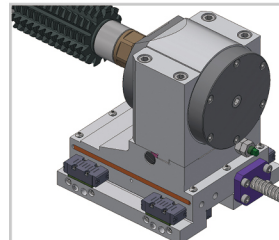

Linear roller bearing

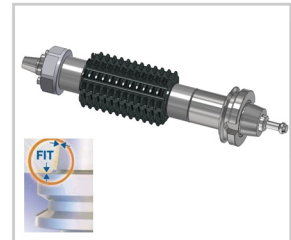

Dual contact Hob arbor

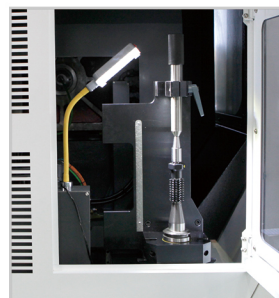

Hob presetter



Hob head Assembly

High rigidity tail stock

- ▶ By using strong cast frame and high rigidity roller guide, high precision gear cutting is possible while heavy cutting

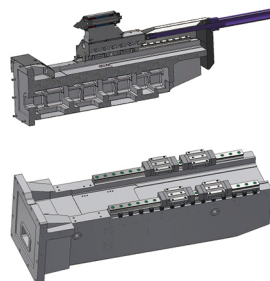

Tail stock Assembly

High rigidity, High torque, High precision table

- ▶ No Backlash Table with the application of High Torque Direct-Drive Motor and Precision Encoder, it guarantees high Cutting Accuracy

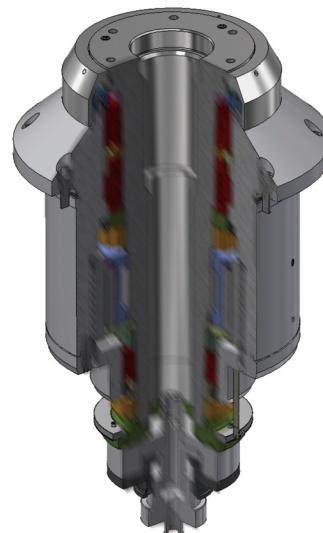
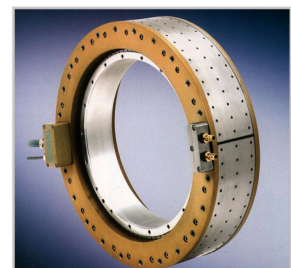

Table Assembly



High Torque Direct-Drive Motor



Precision Encoder

Features of Machine body

Angled Wide Slide Way

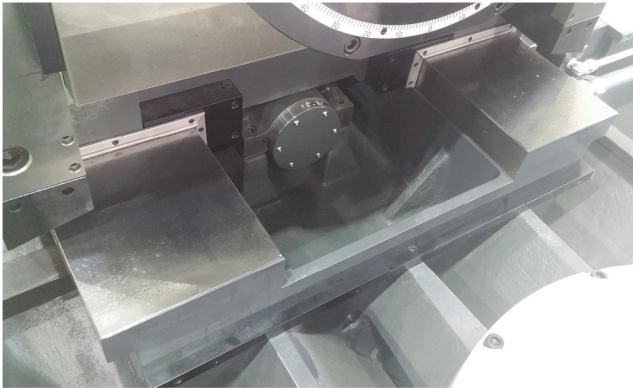

X-axis Slide Way

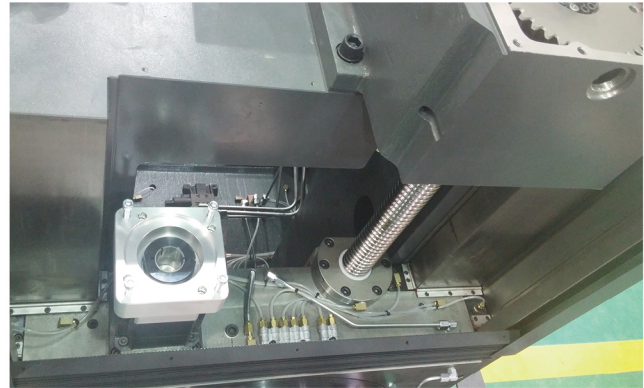

Z-axis Slide Way

- ▶ With the adoption of the Wide Slideway angled structure into the bed and column, it allows precise work based on the lowered surface pressure and high cutting resistance

Optimized Structure

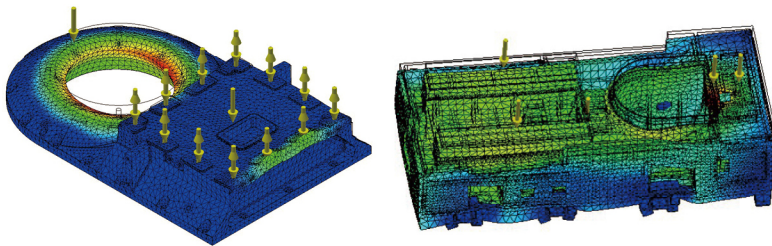

- ▶ Optimized Structure by Structural Analysis (FEM)

Support Wet cutting and Dry cutting

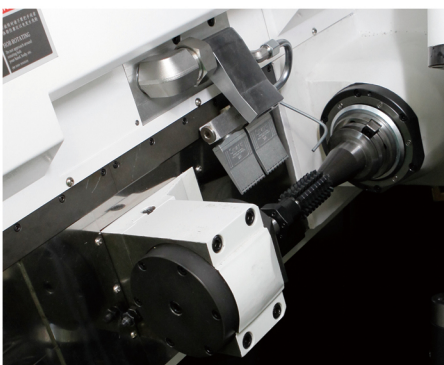

High pressure air nozzle & Coolant nozzle



Inner SUS guard

- ▶ This machine is Designed for Wet or Dry Cutting
- ▶ Slope type bed provide the best Chip disposal condition
- ▶ High pressure air nozzle and SUS guard on the bed provide Optimized Dry cutting system and High Thermal stability

SH210/260/310/410 'Cassiopeia'

For Your Future

Long Shaft Cutting

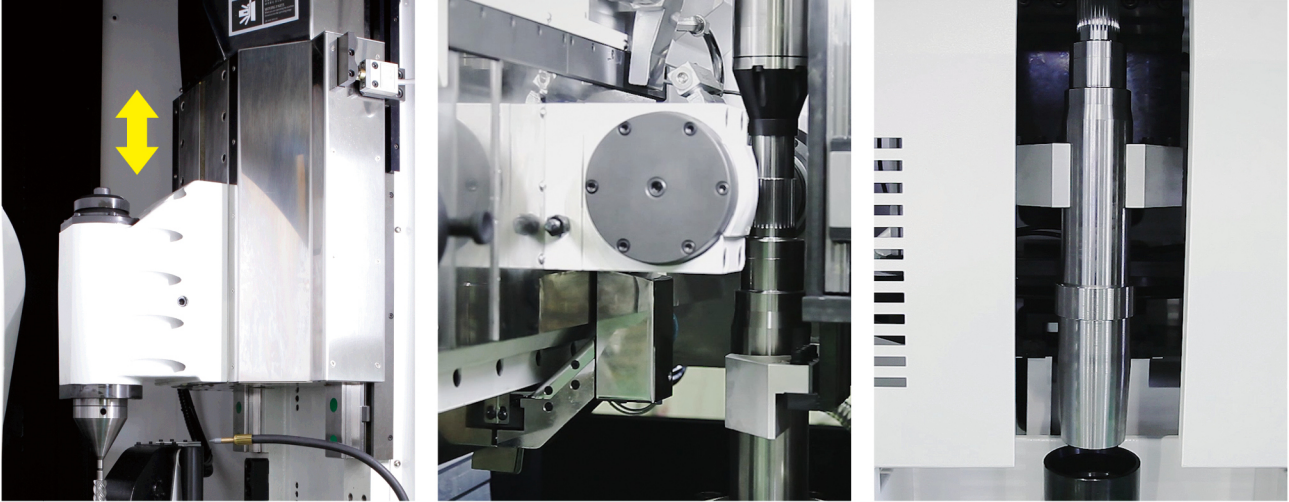

► It is designed to adjust tailstock position for long shaft cutting and up to 650mm shaft can be automated using ring loader

Dialogue Program and Hobbing Cycle

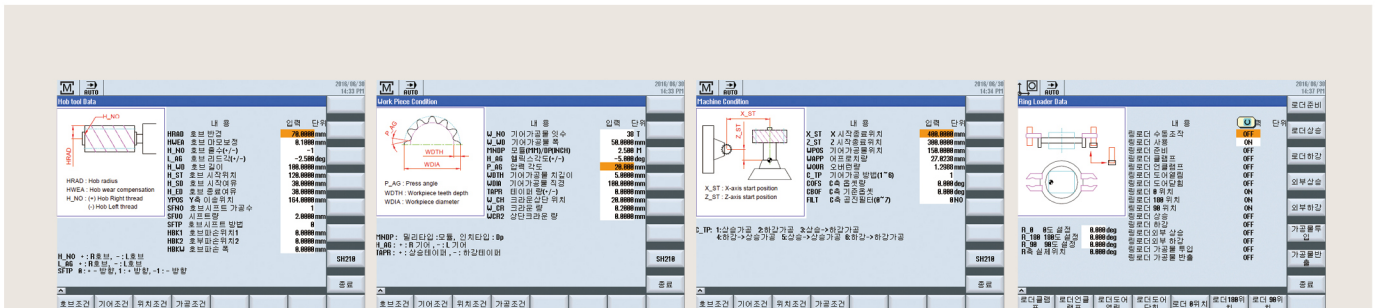

► By utilizing the Easy dialogue programming environment, additional programming is not necessary and gear processing is easy with just the input of specifications of hob cutter, workpiece, and cutting condition

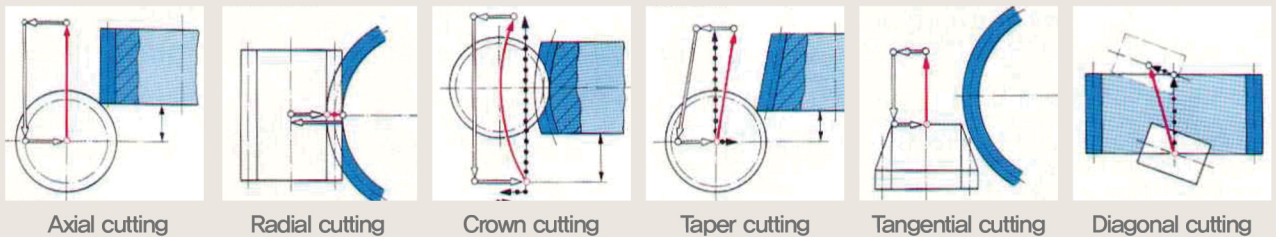

► This machine can use not only crown gears and taper gears, but also all hobbing cycles applied to gear cutting (axial cutting, radial cutting, tangential cutting and diagonal cutting)

Optional Accessories

Automation

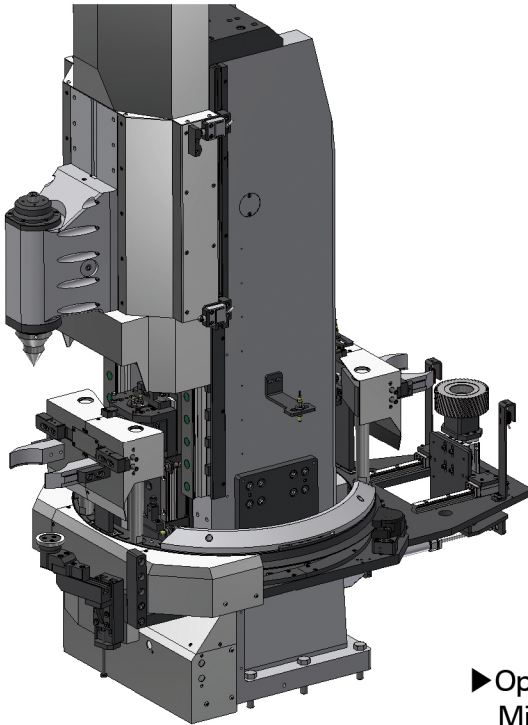

STD. Ring Loader



Stocker Conveyor

► Optimized Ring Loader and Stocker Conveyor guarantees Minimum space and maximum Productivity

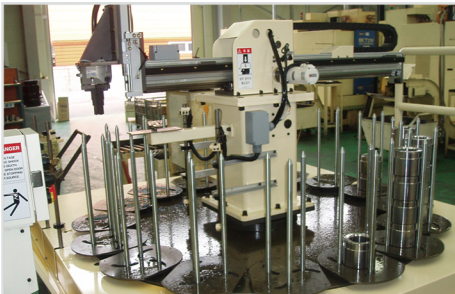

Gantry & Stocker



In/Out Stocker

► Various In/out stocker are Possible



Robot Automation



Customized Automation Line

► Various automation of customer specification is possible (Robot, Gantry loader, Customized Automation Line)

SH210/260/310/410 'Cassiopeia'

For Your Future

Chamfering & Deburring Device

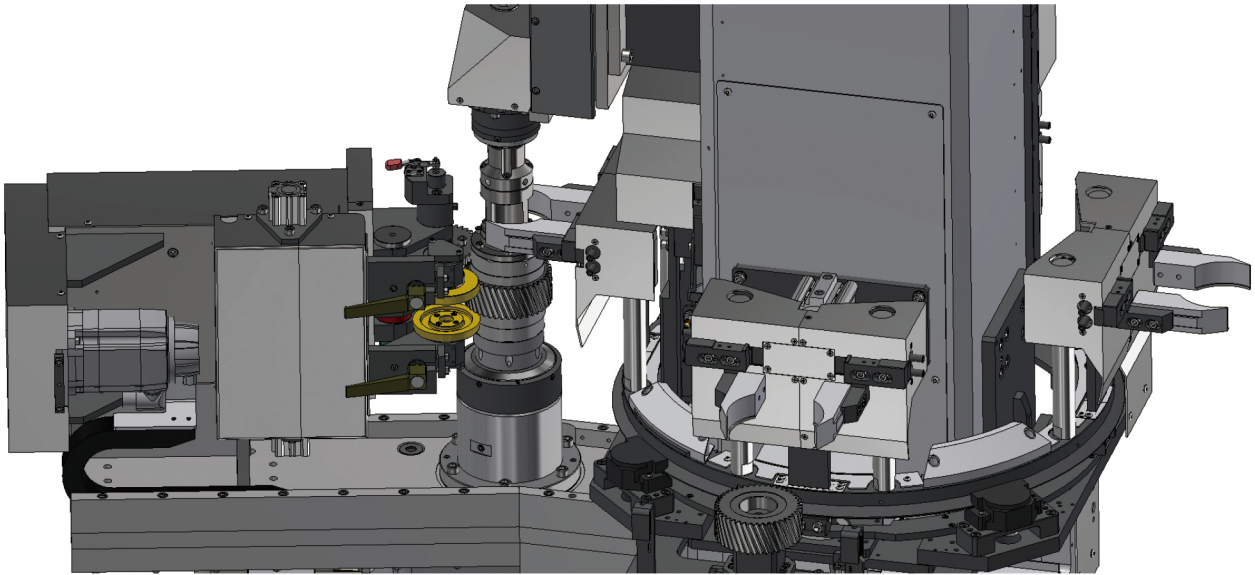

4-Station Ring Loader & Chamfering/Deburring Device

- ▶ The rotary chamfering / deburring device installed inside the machine with a high-speed 4-station ring loader provides maximum cost savings and space saving to customers with its compact design.
- ▶ Since the chamfering / deburring process is performed simultaneously with the hobbing process, the cycle time is not increased.(time-parallel)
- ▶ Provide Completely integrated process with centralized control.

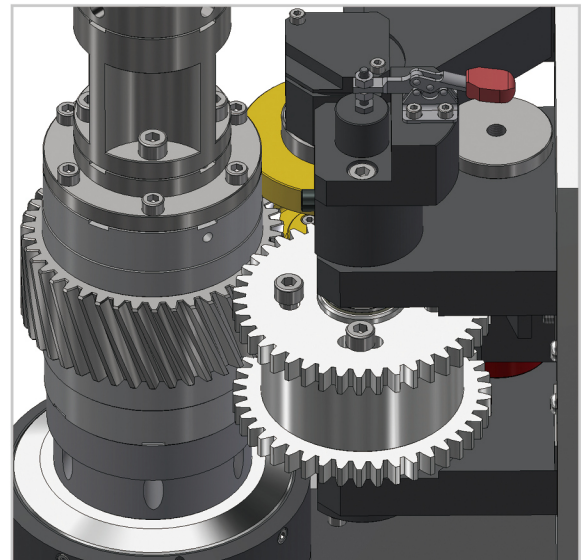

Before Chamfering/Deburring

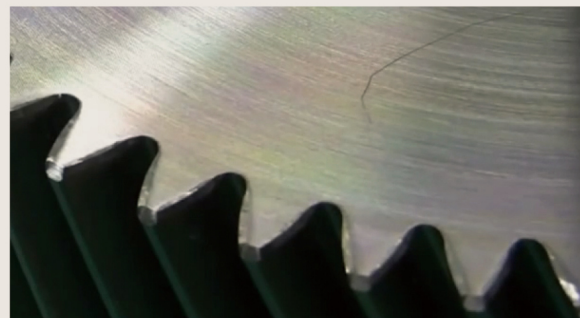

After Chamfering/Deburring

Support the Chamfer cut

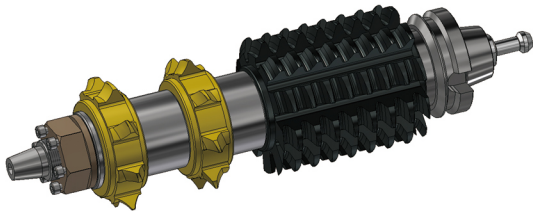
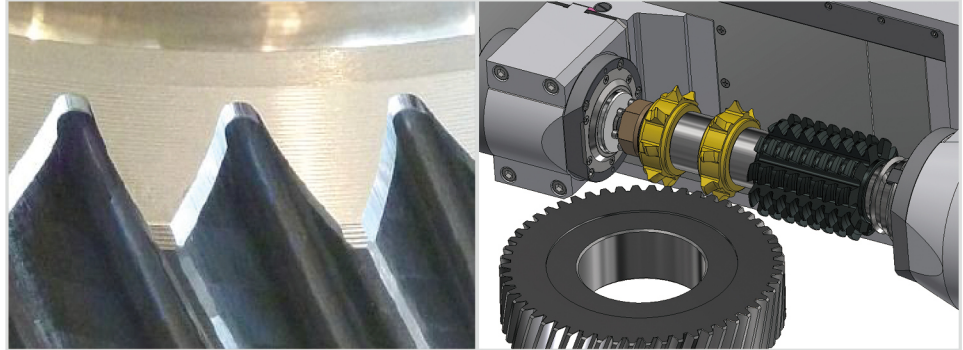

- ▶ Chamfer cut function for high-quality chamfering after hobbing is supported.
- ▶ Using 3D simulation, it checks the interference between chamfer cut cutter, hob cutter and workpiece, and supports the customer to easily and efficiently perform the chamfer cut.



Tool Monitoring System

- ▶ By monitoring the wear and breakage of the hob using tool monitoring system, tool life can be optimized.

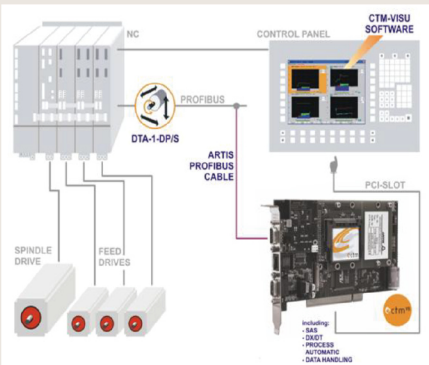
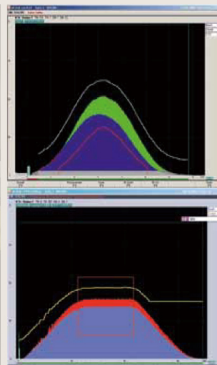

SH210/260/310/410 'Cassiopeia'

For Your Future

Optional Accessories

Skiving unit



►By applying Skiving Sensing unit, High quality Skiving is possible.

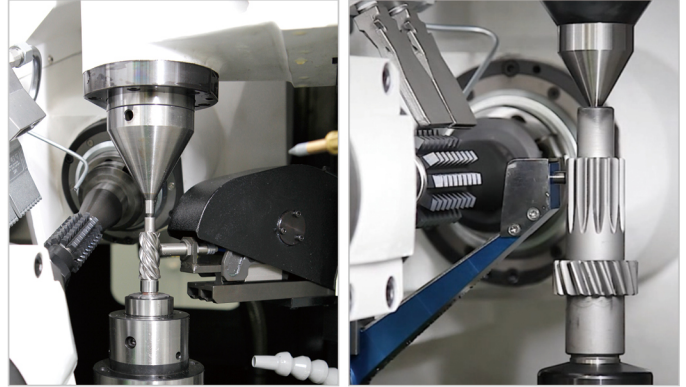

Skiving Sensing unit

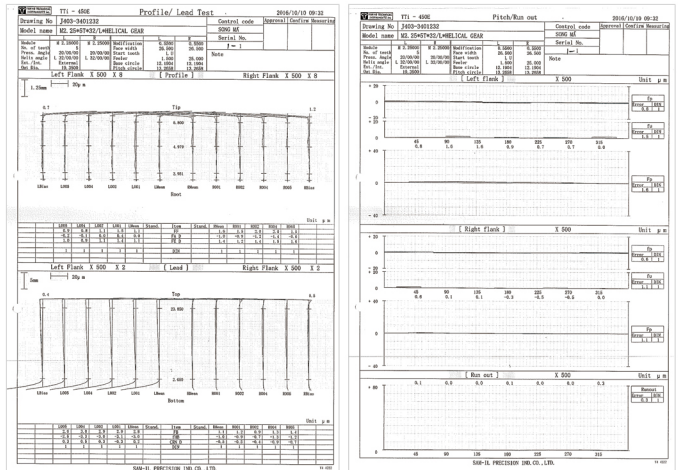

Tooth profile chart (Module 2.25, Number of teeth 5EA, Helix angle 32°)

Oil Mist Collector



Magnetic Chip Separator & Coolant Tank



Coolant Oil Cooler

Used for wet cutting.



MQL unit - Minimum Quantity Lubrication

Used for dry cutting.



Deburring unit

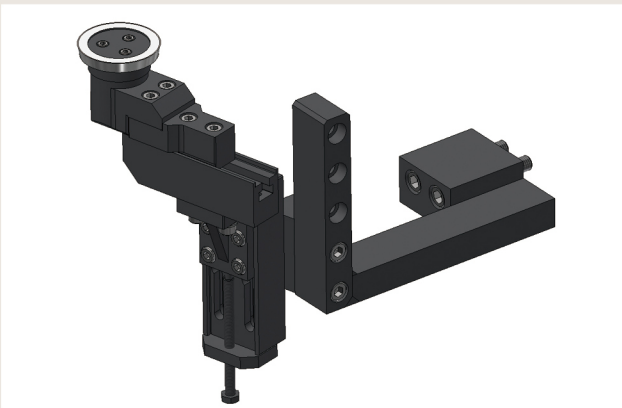

Hob Arbor



Hob Cutter/Chamfering Cutter

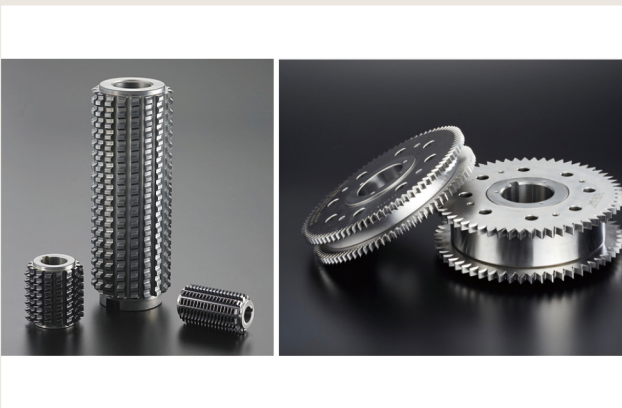

Hobbing Jig/Chamfering Jlg



Machine Specification

Model	SH210	SH260	SH310	SH410
Machine Capacity				
Max. Workpiece Dia. (Automation)	Φ210 mm	Φ260 mm	Φ310 mm	Φ410 mm
Max. Workpiece Dia. (Manual)	Φ350 mm	Φ350 mm	Φ350 mm	Φ410 mm
Max. Module	M6	M6	M6	M8
Max. Table Speed	300 rpm	300 rpm	300 rpm	200 rpm
Table Dia.	Φ240 mm	Φ240 mm	Φ240 mm	Φ330 mm
Base Jig Dia.	Φ130 mm	Φ170 mm	Φ210 mm	Φ260 mm
Hob Head				
Max. Hob Dia. Length	Φ180/220 mm	Φ180/220 mm	Φ190/230 mm	Φ190/230 mm
Max. Hob Speed	2000 rpm	2000 rpm	1500 rpm	1000 rpm
	(Opt.1000rpm, 1500rpm)	(Opt.1000rpm, 1500rpm)	(Opt.1000rpm, 2000rpm)	(Opt.1500rpm, 2000rpm)
Max. Hob Shift (Y-axis) Travel	200 mm	200 mm	210 mm	210 mm
Hob Swivel Angle	±45°	±45°	±45°	±45°
Hob Arbor Taper	BBT #40	BBT #40	BBT #40	BBT #40
Hob Spindle Output	12 kW	12 kW	12 kW	15 kW
Working Range				
X-axis Travel (Radial)	270(15~285) mm	270(15~285) mm	270(15~285) mm	290(15~305) mm
Z-axis Travel (Axial)	370(200~570) mm (Opt. 600(200~800)mm)	370(200~570) mm (Opt. 600(200~800)mm)	370(200~570) mm (Opt. 600(200~800)mm)	370(150~520) mm (Opt. 600(150~750)mm)
Tail stock Center Travel	400(355~755)mm	400(355~755)mm	400(355~755)mm	400(305~705)mm
Rapid				
X-axis Rapid (Radial)	12 m/min	12 m/min	12 m/min	12 m/min
Z-axis Rapid (Axial)	12 m/min	12 m/min	12 m/min	12 m/min
Y-axis Rapid (Tangential)	5 m/min	5 m/min	5 m/min	5 m/min
Other Specification				
Number of Axes	6(X,Y,Z,A,B,C)	6(X,Y,Z,A,B,C)	6(X,Y,Z,A,B,C)	6(X,Y,Z,A,B,C)
CNC Control System	Siemens 840D SL	Siemens 840D SL	Siemens 840D SL	Siemens 840D SL
Full splash guard type	Close top	Open top	Open top	Open top
Floor Space (L x W x H)	2741 x 3238 x 2970 mm	2741 x 3238 x 2990 mm	2741 x 3238 x 2990 mm	2776 x 3329 x 2990 mm
Machine Weight	9500 kg	9500 kg	9500 kg	11000 kg

Working Area

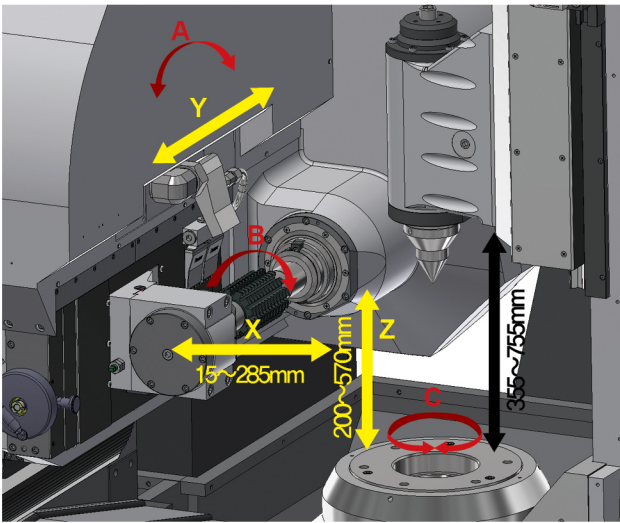

- ▶ X Radial slide movement
- ▶ Y Tangential slide movement
- ▶ Z Vertical slide movement
- ▶ A Hob head swivel
- ▶ B Hob spindle rotation
- ▶ C Work table rotation

Standard Accessories

- Machine Body
- Full Splash Guard
- Inner SUS Cover & Air blow
- Hob Arbor Set)
- Wet & Dry Cutting System
- Hydraulic Unit
- Lubricating Pump & Tank
- C-axis Oil Cooler
- LED Work Light
- Standard Base Jig
- Hob Presetter
- Standard tools & Box
- Ele. Cabinet Air conditioner
- UPS Set for Retract
- Leveling bolt & Base plate
- Operating Manual
- MPG(Manual Pulse Generator)



Optional Accessories

- Oil Mist Collector
- Hob Arbor Set
- Magnet Chip Separator & Coolant Tank
- Auto Door
- Deburring unit
- Work Rest
- Coolant Oil Cooler
- MQL(Minimum Quantity Lubrication) Unit/MQL
- Skiving unit
- Z-axis Stroke Extension(370mm->600mm)(370mm->600mm)
- Tool Monitoring System
- Linear Scale(X-axis)
- Air Catching System
- Transformer
- STD. Ring Loader
- 4-Station Ring loader
- Stocker Conveyor(Pallet type)
- Chamfering & Deburring Device
- Chamfering Jig
- Chamfering Cutter
- Hobbing Jig
- Hob Cutter
- Chamfer Cut Function
- Chamfer Cut Cutter
- Automation

Machine layout

SH210

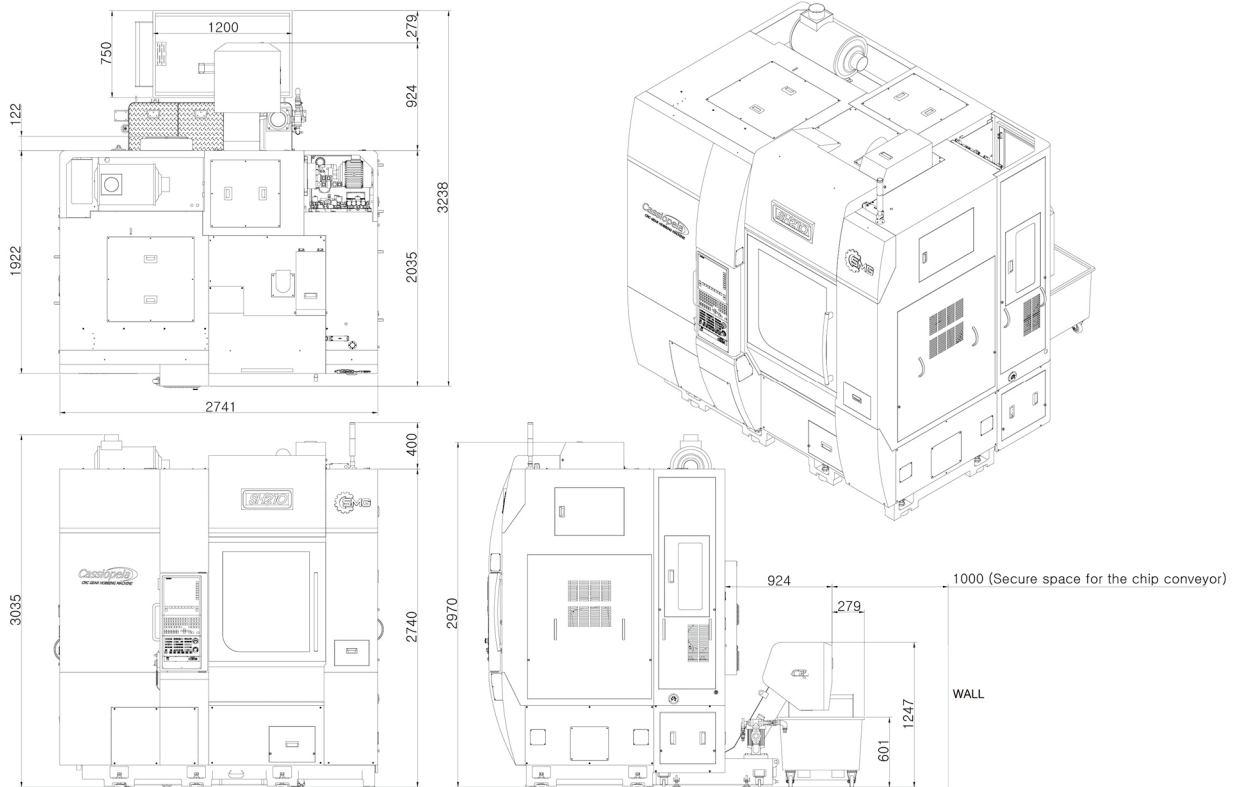

SH260

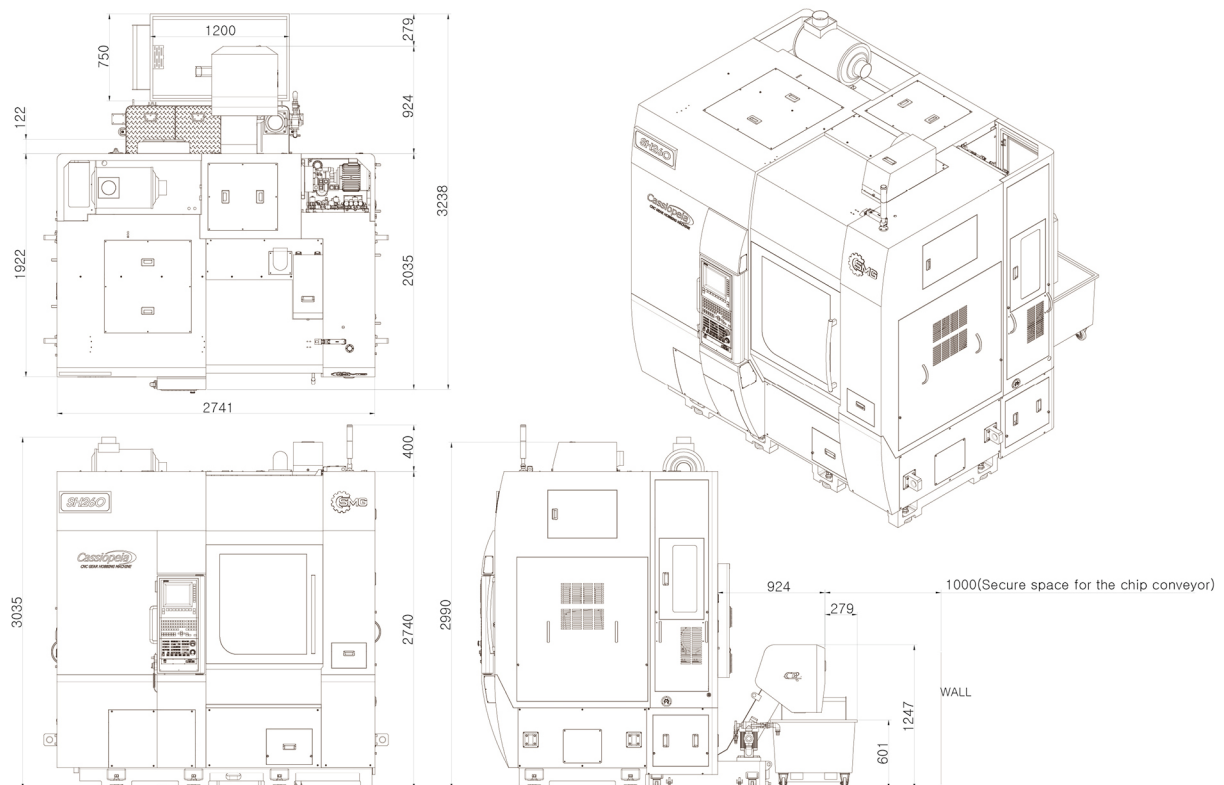

SH310

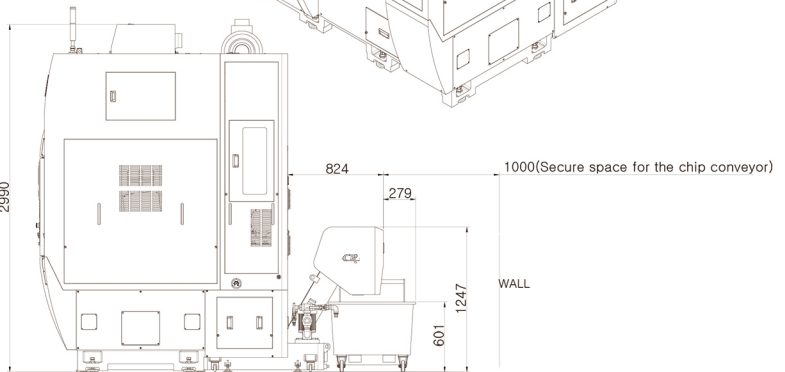
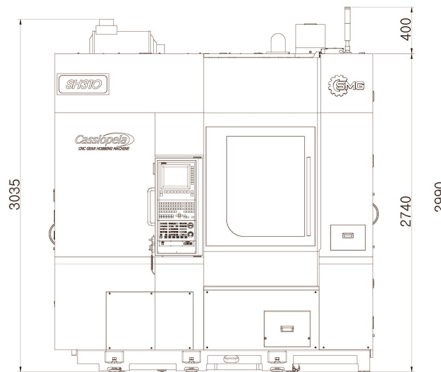
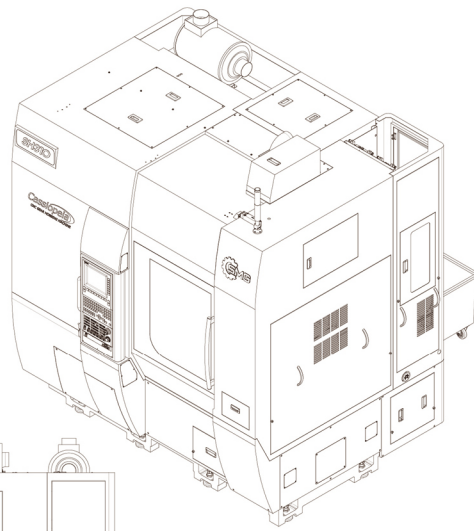
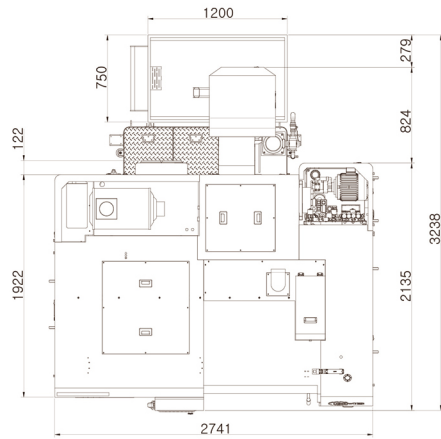

SH410

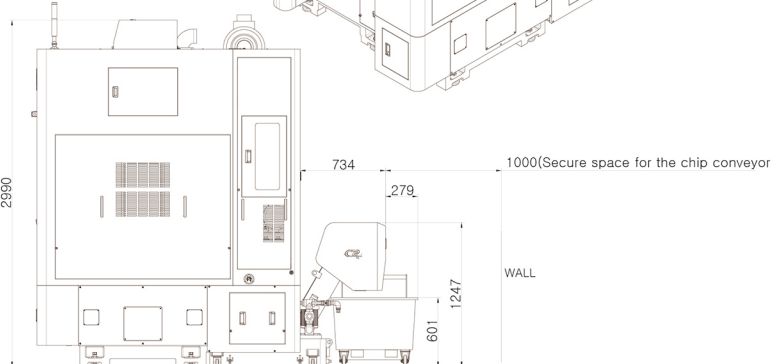
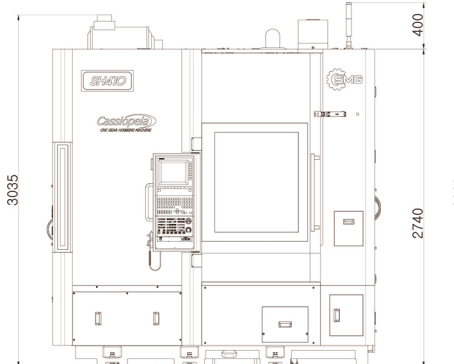
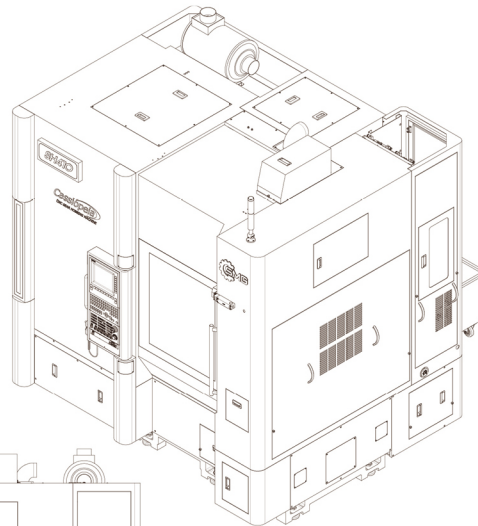
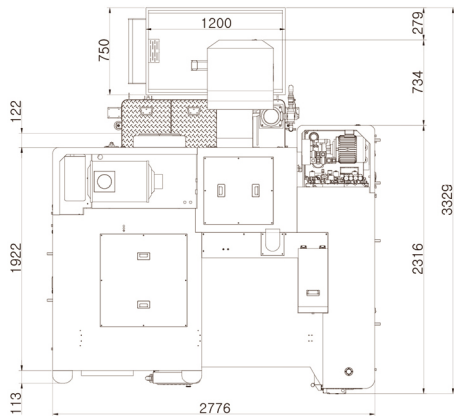

**SMG provides the best solutions and services
for gear cutting to worldwide customers.**



www.songma.co.kr



SONG MA CO.,Ltd

120, Changgok-ro, Seongsan-gu, Changwon-si,
Gyeongsangnam-do, Korea

E-mail : sales@songma.co.kr

everhee2@naver.com

Tel : +82-55-266-5014,5016 **Fax :** +82-55-266-5017

Overseas official agent